

INSTALLATION INSTRUCTIONS

OPERATION & MAINTENANCE

FOREWORD

The following information is to be used by the installer as a guide. Since each installation is unique unto itself, only general topics are covered. The order in which topics are presented may not be those required by the actual installation.

This guide does NOT supersede or circumvent any applicable national, state or local codes.

The installation is to be performed only by individuals whose experience meets or exceeds the requirements of the work involved.

The installer MUST read the entire contents of this guide and develop a thorough understanding before beginning.

Due to a continuing program of product research, MAGIC AIRE reserves the right to discontinue or change without notice, any or all specifications or designs without incurring obligations.

INSPECTION

Thoroughly inspect all packages upon receipt. Ensure carton(s) have not been dropped, crushed or punctured. Inspect all contents for damage. If damage is found, immediately file a claim with the delivering carrier.

SAFETY

The installation and/or servicing of comfort conditioning equipment can be hazardous due to system pressures and electrical devices.

**ONLY TRAINED/QUALIFIED PERSONNEL
SHOULD PERFORM SERVICE AND/OR
INSTALLATION**

**OBSERVE ALL PRECAUTIONS AND
WARNINGS IN PRODUCT
DATA OR ATTACHED TO THE UNIT.**

Follow all safety codes. Wear eye protection and gloves. Have a fire extinguisher readily available.

**DISCONNECT ALL POWER SUPPLIES
BEFORE ACCESSING EQUIPMENT.**

**DISCONNECTING MORE THAN ONE
POWER SUPPLY MAY BE REQUIRED TO
DE-ENERGIZE SOME EQUIPMENT.**

ELECTRIC SHOCK CAN CAUSE DEATH

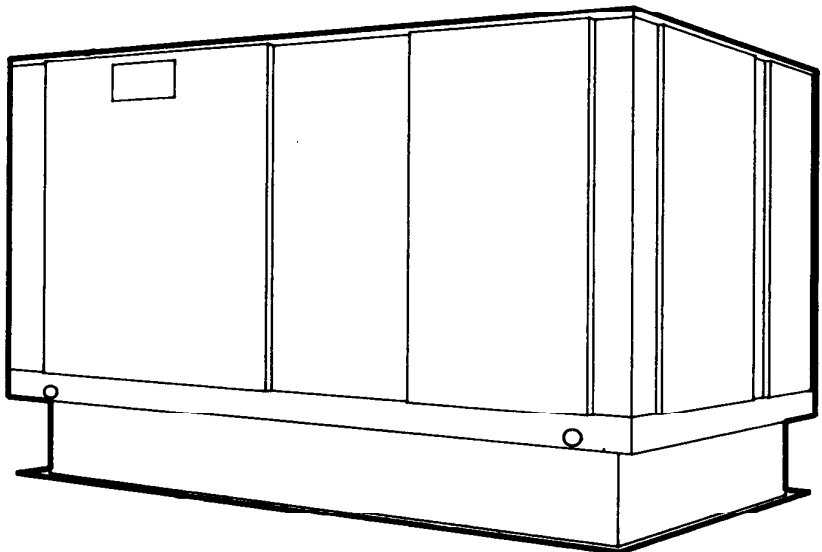

MAGIC AIRE DIVISION OF UNITED ELECTRIC CO.. LP

PRODUCT DESCRIPTION

MODEL NUMBER IDENTIFICATION

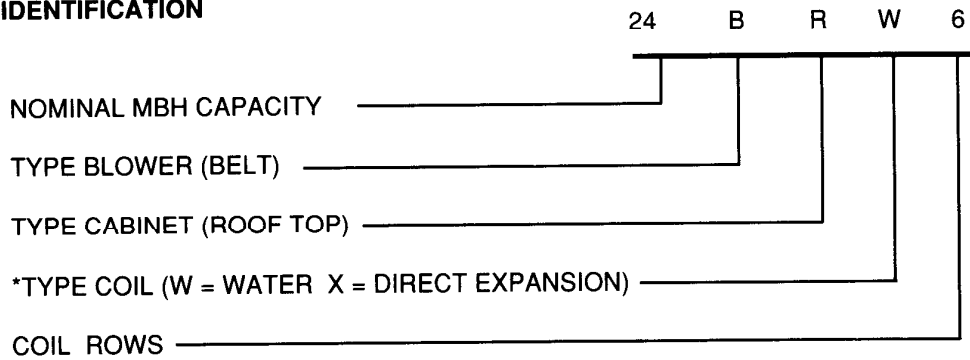

STANDARD FEATURES BR Series

1. All exposed panels are fabricated of 18 ga. galvanealed steel with baked-on enamel paint providing maximum corrosion protection.
2. Cabinet is completely insulated with 3/4" - 1.5# density fiberglass insulation.
3. Supply air fan is DWDI forward curve stocked in down discharge configuration with horizontal discharge optional (allow 2 weeks for conversion).
4. 200,000 hour average life ball bearings for dependable fan operation.
5. Water coils, cooling and heating, are fabricated of copper tube and aluminum fin material. Refrigerant coils, cooling only, are fabricated of rifled copper tube and lanced aluminum fin.
6. Drain pan can be field piped directly to the outside or down through the piping chase provided inside unit for areas with severe winter conditions.
7. Standard filters are 2" throwaway with 2" 30-30 pleated filters as an option.
8. Optional factory roof curb is shipped knocked down for field assembly.
9. Optional weatherhoods for 100% outside air or 100% full modulating economizer complete with factory mounted and wired controls are shipped loose for field installation.
10. Optional manual minimum outside air damper is shipped loose for field installation.

Magic Aire® ROOF TOP AIR UNITS BRW/BRX Series

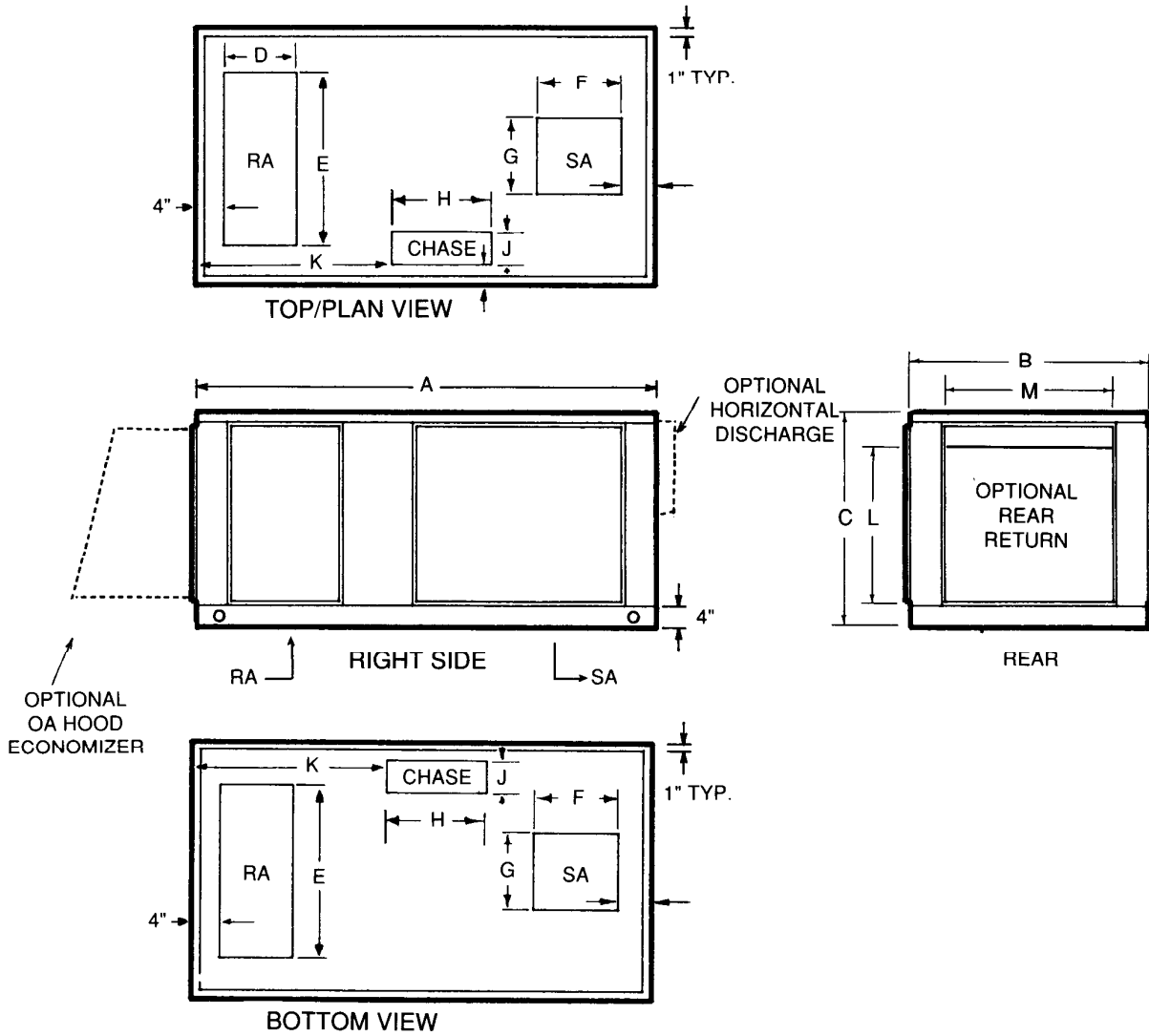

DIMENSIONS												
MODEL	A	B	C	D	E	F	G	H	J	K	L	M
24BR*	67.3	39.5	21.5	12.0	26.0	10.8	12.4	10.0	6.0	34.5	14.2	28.4
36BR*	67.3	39.5	21.5	12.0	26.0	10.8	12.4	10.0	6.0	34.5	14.2	28.4
48BR*	72.0	48.0	25.5	14.0	34.0	11.9	13.6	10.0	6.0	34.5	19.0	36.0
60BR*	72.0	48.0	25.5	14.0	34.0	11.9	13.6	10.0	6.0	34.5	19.0	36.0
90BR*	75.0	53.0	40.5	14.0	44.0	16.4	19.1	15.0	8.0	41.2	23.0	46.1
120BR*	75.0	53.0	40.5	14.0	44.0	16.4	19.1	15.0	8.0	41.2	23.0	46.1
180BR**	75.0	53.0	40.5	14.0	44.0	16.4	37.6	15.0	8.0	41.2	33.0	46.1
240BR**	80.0	62.0	47.0	14.0	64.0	16.4	44.2	15.0	8.0	42.1	40.0	48.0

*W = WATER X = REFRIGERANT

**New Product consult factory for availability.



ROOF TOP AIR UNITS BRW/BRX Series

BRW

SPECIFICATIONS							
MODEL	NOM CAP	NOM CFM	FA SQ FT.	WATER COIL CONNECTION SIZE			FILTERS
				4 ROW	6 ROW	2 ROW	
24BRW	2	800	2.0	3/4" OD SWT	3/4" OD SWT	5/8" OD SWT	(2) 16x20
36BRW	3	1200	3.0	3/4" OD SWT	7/8" OD SWT	7/8" OD SWT	(2) 16x20
48BRW	4	1600	4.0	7/8" OD SWT	1 1/8" OD SWT	7/8" OD SWT	(2) 20x20
60BRW	5	2000	5.0	1 1/8" OD SWT	1 1/8" OD SWT	1 1/8" OD SWT	(2) 20x20
90BRW	7.5	3000	8.1	1 3/8" OD SWT	1 5/8" OD SWT	1 1/8" OD SWT	(4) 16x20
120BRW	10	4000	9.5	1 3/8" OD SWT	1 5/8" OD SWT	1 1/8" OD SWT	(4) 16x20
180BRW	15	6000	13.3	1 3/8" OD SWT	1 5/8" OD SWT	1 3/8" OD SWT	(4) 20x25
240BRW	20	8000	17.7	(2) 1 5/8" OD SWT	(2) 1 5/8" OD SWT	(2) 1 1/8" OD SWT	(4) 20x20 (2) 20x25

BRX

SPECIFICATIONS							
MODEL	NOM CAP	NOM CFM	FA SQ FT.	COIL CONNECTION SIZE			FILTERS
				LIQ. LINE	SUCT. LINE	2 ROW WATER	
24BRX	2	800	2.0	3/8" OD SWT	3/4" OD SWT	5/8" OD SWT	(2) 16X20
36BRX	3	1200	3.0	3/8" OD SWT	3/4" OD SWT	7/8" OD SWT	(2) 16X20
48BRX	4	1600	4.0	1/2" OD SWT	7/8" OD SWT	7/8" OD SWT	(2) 20X20
60BRX	5	2000	5.0	1/2" OD SWT	1 1/8" OD SWT	1 1/8" OD SWT	(2) 20X20
90BRX	7.5	3000	8.1	5/8" OD SWT	1 1/8" OD SWT	1 1/8" OD SWT	(4) 16X20
120BRX	10	4000	9.5	5/8" OD SWT	1 3/8" OD SWT	1 1/8" OD SWT	(4) 16X20
180BRX	15	6000	12.8	7/8" OD SWT	1 3/8" OD SWT	1 3/8" OD SWT	(4) 20X25
240BRX	20	8000	17.7	(2) 5/8" OD SWT	1 3/8" OD SWT	(2) 1 1/8" OD SWT	(4) 20x20 (2) 20x25

*Specifications in this publication subject to change without notice due to continuing effort to improve our product.

AVAILABLE MOTORS (60 Hz)

HORSE POWER	VOLTAGE/PHASE
1/4, 1/3	115/1 Split Phase
1/4, 1/3, 1/2, 1, 1 1/2, 2	115/208-230/1
1/4, 1/3, 1/2	115/1 2 SPD
3/4	230/1 2 SPD
1/4, 1/3, 1/2, 1	277/1
1/3, 1/2, 1, 1 1/2, 2, 3, 5	208-230/460/3

For service assistance, the unit Model number, serial number and/or sales order must be provided.

For motors not listed contact factory.

Magic Aire®

**ROOF CURB/ROOF TOP AIR UNITS
BRW/BRX Series**

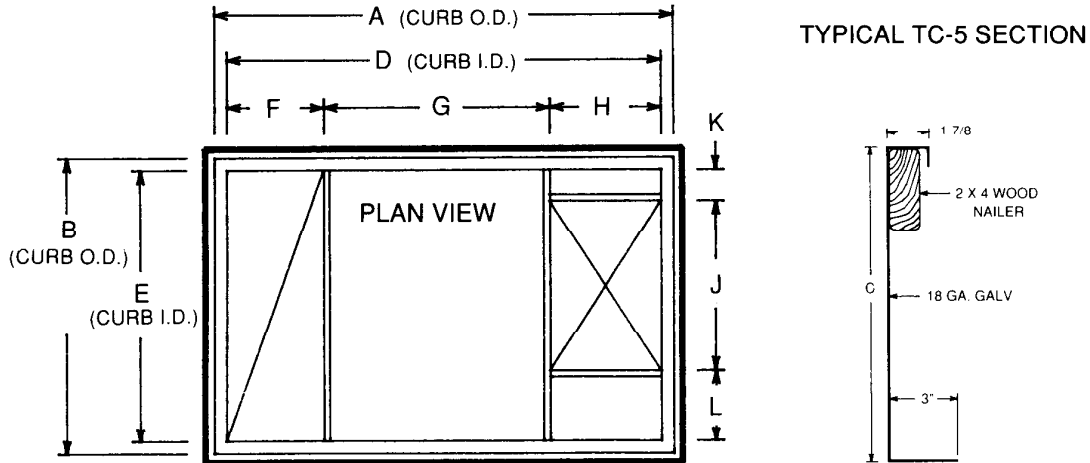

DIMENSIONS

MODEL	A	B	C	D	E	F	G	H	J	K	L
RC-024036	63.88	36.00	14.00	60.13	32.25	13.63	33.38	13.13	20.00	6.13	6.13
RC-048060	69.00	44.50	14.00	65.25	40.75	14.63	34.00	16.63	25.50	4.63	10.63
RC-090120	71.50	49.50	14.00	67.75	45.75	15.63	33.25	18.88	30.75	5.63	9.38
RC-180*	71.50	49.50	14.00	67.75	45.75	15.63	33.27	18.88	30.75	5.63	9.38
RC-240*	76.50	78.50	14.00	72.75	74.75	18.88	33.00	20.88	48.75	11.50	11.50

New Product consult factory of availability.

ARRANGEMENTS

RETURN

DISCHARGE

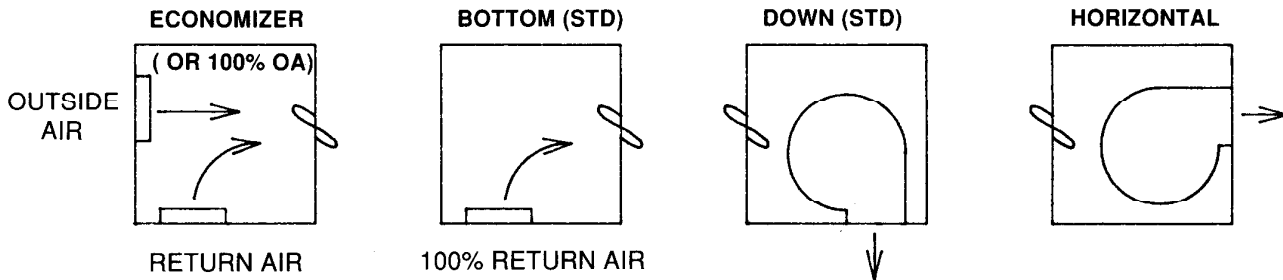

UNIT AND ACCESSORIES SHIPPING WEIGHTS

MODEL	**2 ROW	DX	4 ROW	6 ROW
24 BR	13	280	280	290
36 BR	18	280	280	290
48 BR	25	315	315	340
60 BR	30	380	410	420
90 BR	40	530	540	550
120 BR	45	555	580	590
180 BR*	55	710	745	760
240 BR*	75	915	950	970

MODEL	BREP	RC	MOAD
24/36	90	85	50
48/60	135	95	95
90/120	175	105	125
180*	175	105	125
240*	200	120	145

**Coil Only

INSTALLATION

Step 1 - Ductwork

Use accepted industry practices and design guidelines of the ASHRAE FUNDAMENTALS HANDBOOK. Ductwork must comply with all building codes and the NATIONAL FIRE PROTECTION ASSOCIATION's pamphlet 90A and 90B.

Carefully inspect any previously installed ductwork to determine suitability.

Note: Ductwork should be of a size meeting requirements of the installation. Ductwork should transition gradually from a smaller size blower outlet to required duct run size to avoid excessive loss of air velocity.

Step 2 - Check duct insulation and vapor proofing

Previously installed heating supply ductwork may already have adequate insulation against excessive heat loss. This insulation may be satisfactory for protection against heat gain from summer cooling. Depending upon application, it may be required to add more insulation.

Externally insulated ductwork must have adequate vapor seal for summer operation, particularly where duct is exposed to high humidity conditions such as in attic, vented crawl space, unconditioned basement or utility room.

Step 3 - Ductwork

1. When return air duct connection is smaller than coil inlet opening, construct the transition piece so that vertical and horizontal dimensions of transition do not increase more than one inch for every 7 inches of length.

2. Allow a minimum of 3 feet of straight ductwork preceding equipment inlet.

3. Install unit with 1/8 inch pitch toward condensate drain opening.

Step 4 - Sound Attenuation

Flexible duct connections should be used between the unit and both the supply and return ducts. Unit vibration isolation will be required for both suspended and base mounted units.

Step 5 - Installation of Condensate Drain

Condensate drain must consist of a minimum of 3/4 inch copper tubing or 3/4 inch galvanized iron pipe or PVC-type plastic pipe. (Fig.1.) The condensate drain trap must be properly designed to ensure the removal of condensate (Incorrect trapping can hold water in pan causing overflow.) Be sure drain pitches downward at a slope of one inch every 10 feet.

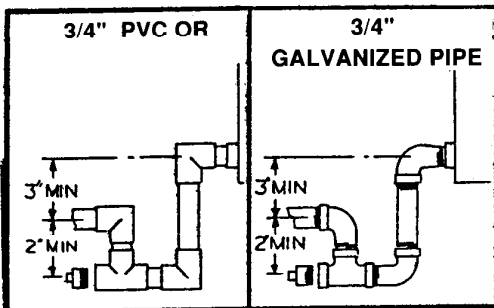

Fig. 1

Note: Consult local codes for additional precautions before installing condensate drain.

Step 6 - Direct Expansion Refrigerant Piping

Always use the condensing unit manufacturer's recommended line sizes. The suction line must be insulated for satisfactory operation. Observe all condensing unit manufacturer's recommendation or requirements. Use refrigerant grade copper only. If unit is to be used when installed as the indoor coil of a heatpump, a by-pass check valve must be used.

Note: It is recommended that a freeze-stat (by other) be installed when a hot water coil is used and is mounted in the reheat position.

(Fig. 2) below shows the basic installation of a TXV and the location of the sensing bulb.

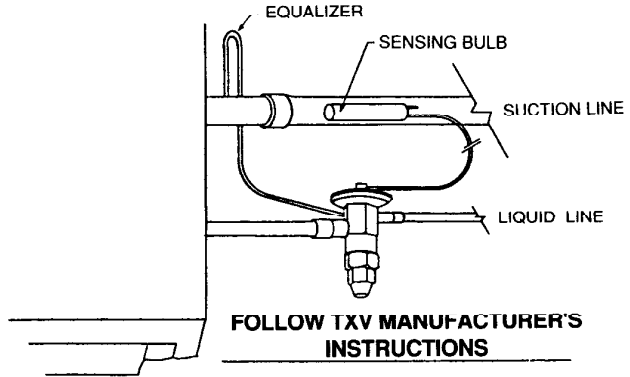

Fig. 2

Step 7 - Water Piping

All piping must be supported independent of coils. Swing joints or flexible fittings must be provided to absorb expansion and contraction strains. Rigid piping reduces the effectiveness of vibration isolators. The water supply should always be connected so that the entering water is on the leaving air side of the coil (Fig. 3.) Coils must be adequately vented in order to prevent air binding. Freeze-ups due to low air temps. are not covered under the Magic Aire Warranty.

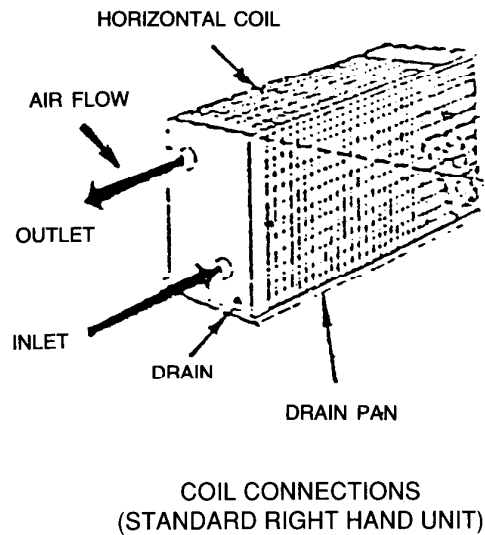

Fig. 3

Step 8 - Motors and Drives

Units will normally be shipped with motor and drive installed. However, when mounting a motor on the adjustable base in the field, extreme care should be taken to ensure proper alignment and belt tension.

Step 9 - Electrical Connections

A control box is mounted on each unit and the motor is to be wired to this box.

Note: Unit must be permanently grounded in accordance with NEC and local codes and ordinances. See typical wiring diagram. (Fig. 4.)

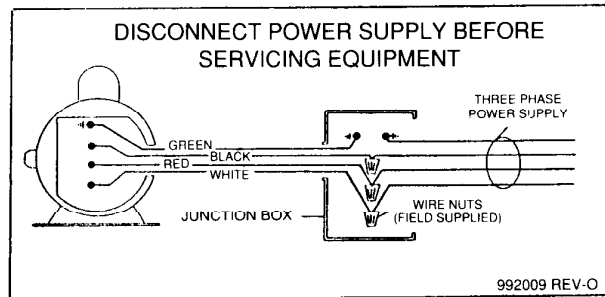
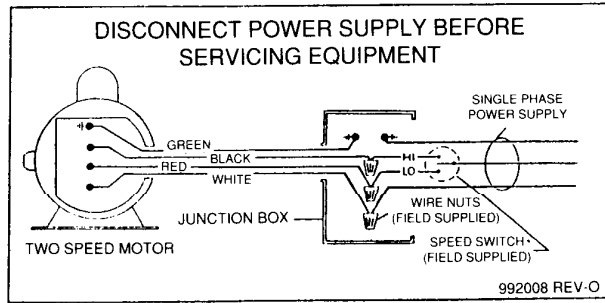
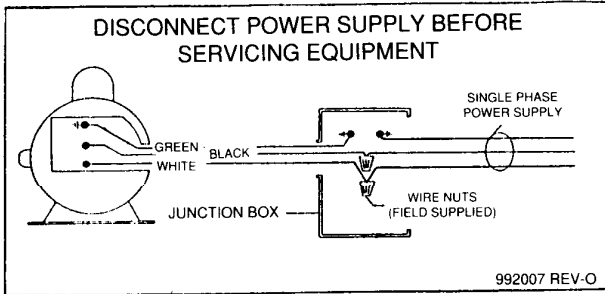

Fig. 4

START-UP

Ensure all shipping bolts/screws are removed and all other bolts and screws tight. Never assume the voltage and phase on the unit name plate is the same as the motor is wired. Check the sheaves to see if they are in alignment and ensure the set screws are tight. Check for proper rotation of the blower pulley. Three phase motor rotation can be reversed by exchanging two of the three leads at the unit j box. Not all installations will be on starter. The rotation of single phase motors can be reversed by exchanging leads inside the motor junction box. Refer to motor nameplate. Ensure all filters are installed. Do this with all doors, panels, etc. in place. Check the amperage draw of the motor. This should not exceed the nameplate amps shown on the motor serial plate.

OPERATION AND MAINTENANCE

WARNING

Disconnect electrical power to all circuits before servicing unit. Failure to do so may result in personal injury from electrical shock or moving parts.

RETURN AIR FILTERS

Filter access is from either side of unit. Inspect on a regular basis (at least monthly) and clean or replace.

CAUTION

Never operate unit without a filter or with filter access door removed. Damage to blower motor may result.

Step 8 - Water Piping - All Drain

Coil is easily cleaned when dry. To check or clean, remove unit access panel, filter access door and filter. Use accepted industry methods for cleaning. Remove all foreign matter from pan and condensate drain line. Check for rust and holes.

BELT AND PULLEY

Proper pulley alignment and belt tension must be maintained at all times. Speed is reduced by adjusting pulley faces so they are further apart; speed is increased with faces closer together. Check pulley set screws and bolts.

MOTOR

Use electric motor oil or SAE20 nondetergent oil. Tighten motor mount bracket and base bolts as required. **DO NOT OVER-OIL!!**

BLOWER

Check bearing for wear. Replace as required. Check wheel for accumulation of dirt and clean as required.



ALL PRODUCT LIMITED WARRANTY

ONE-YEAR WARRANTY — This UNITED ELECTRIC CO. product is warranted to be free from defects in material and workmanship under normal use and maintenance for a period of one year from the date of original installation. A new or rebuilt part to replace any defective part will be provided without charge, PROVIDED the defective part is returned to our distributor. The replacement part assumes the unused portion of the warranty.

THIS WARRANTY DOES NOT INCLUDE LABOR or other costs incurred for repairing, removing, installing, shipping, servicing, or handling of either defective parts or replacement parts.

UNITED ELECTRIC CO. WILL NOT BE RESPONSIBLE FOR:

1. Normal maintenance.
2. Damage or repairs required as a consequence of faulty installation or application by others.
3. Failure to start due to voltage conditions, blown fuses, open circuit breakers, or other damages due to the inadequacy or interruption of electrical service.

FOR SERVICE OR REPAIR, FOLLOW THESE STEPS IN ORDER:

FIRST: Contact the installer.

SECOND: Contact the nearest distributor:

THIRD: Contact:

UNITED ELECTRIC CO., LP
MAGIC AIRE DIVISION
501 Galveston St.
Wichita Falls, Texas 76301
Phone: (817) 767-8333

4. Damage or repairs needed as a consequence of any misapplication, abuse, improper servicing, unauthorized alteration, or improper operation.
5. Damage as a result of floods, winds, fires, lightning, accidents, corrosive atmosphere, or other conditions beyond the control of United Electric Co.
6. Parts not supplied or designated by UNITED ELECTRIC CO.
7. UNITED ELECTRIC CO. products installed outside the United States and Canada.
8. ANY SPECIAL, INDIRECT, CONSEQUENTIAL, PROPERTY, OR COMMERCIAL DAMAGE OF ANY NATURE WHATSOEVER.

LIMITATION OF WARRANTIES — THIS WARRANTY IS EXCLUSIVE AND IN LIEU OF ALL OTHER WARRANTIES EXPRESS OR IMPLIED. THE REMEDIES PROVIDED FOR IN THIS WARRANTY ARE EXCLUSIVE AND SHALL CONSTITUTE THE ONLY LIABILITIES ON THE PART OF UNITED ELECTRIC CO.

Model _____ Serial No. _____ Date of Installation _____

Effective on products manufactured after July 4, 1975. Supersedes any other warranty certificates supplied with the product.