



United Electric Company, L.P.  
501 Galveston St.  
Wichita Falls, TX 76301

Phone: (940) 397-2100  
uvsales@magicaire.com

**Part Replacement – Pre-2005**

Due to the vintage of units prior to 2005 and the possibility of field part change outs, a detailed description from the field regarding part's specifications is required for expediency and correctness of part replacements.

The following MUST be confirmed first.

Many parts for vintage units are found in the MAUV & MAUH Vintage Replacement Parts List. This is the first resource for all part requests.

If the part cannot be found in the Parts List, the following must be provided to assist with correct part replacement:

Unit Model (Nameplate) \_\_\_\_\_  
Unit Serial Number (Nameplate) \_\_\_\_\_  
Parts Physical Location and Full description of the part:

For Motors and Transformers the following MUST be provided also:

Unit Voltage (Nameplate) \_\_\_\_\_  
Motor HP (From actual motor being replaced not nameplate) \_\_\_\_\_  
Motor Vendor Part Number \_\_\_\_\_  
ECM Motor Program (From sticker on Cap End of Motor. If no longer on motor, state "Non Existing") \_\_\_\_\_

A picture may be requested if the description does not fully describe the part.

When a part is quoted by Magic Aire, the parts specifications will be given. It is the responsibility of the buyer to confirm all part specification information before placing the order. Please be aware some parts are obsolete and are not possible to replace.

Thank you for your assistance in helping to provide Fast and Precise answers to our Customers!

Magic Aire – UV Sales Team



REPLACEMENT PARTS GUIDE FOR HORIZONTAL AND VERTICAL UNIT VENTILATORS

## MAUH & MAUV A-D VINTAGE SERIES UNITS

Vertical Units - Exterior Panels and Tops	page 3
Horizontal Units - Exterior Panels and Tops	page 4
Water Coils and Low Limit	page 5
DX Coils, Low Limit, and TXVs	page 6
Steam Coils and Vacuum Breaker	page 7
Drainpans	page 8
Blower Shaft, Wheels, Bearings, & Motors	page 9
Motor and Control ECM Harness	page 10
Filters & Touch Up Paint	page 11
Transformers	page 12
Electric Heat Components	page 13
Control Components	page 14
Water valves	page 15
Freight Charge Map	page 16

SEND ORDERS TO:

(940) 397-5603 ORDER FAX

OR

[purchaseorders@magicaire.com](mailto:purchaseorders@magicaire.com)

Lead Time 3 Days Except Where Noted

Items Marked with "SD" Ship Same Day if Order Received by 11:00am CST

All Parts Orders ship 2nd day Air unless Ground noted on Purchase Order

For questions, please contact: [uvsales@magicaire.com](mailto:uvsales@magicaire.com)

SUBJECT TO STANDARD MAGIC-AIRE TERMS AND CONDITIONS

United Electric Company 501 GALVESTON STREET, WICHITA FALLS, TEXAS 76301

**VERTICAL UNITS - PANELS**

Replace X With 1=Beige, 2=Polar Ice, 3=Bronze, 4=White, 6=Gray

Part Number	Description	Fits Series			Page #	ITEM #
073-101352-00X	FRONT CENTER PANEL 16ga	UV-500			3	14
073-102352-00X	FRONT CENTER PANEL 16ga	UV-750				
073-103352-00X	FRONT CENTER PANEL 16ga	UV-1000				
073-104352-00X	FRONT CENTER PANEL 16ga	UV-1250				
073-105352-00X	FRONT CENTER PANEL 16ga	UV-1500				
073-100090-00X	FRONT SIDE PANEL 16ga	ALL				15
RUV0190X	FRONT PANEL FASTENER KIT	ALL		SD		
073-100050-00X	16 5/8" END PANEL - SINGLE	ALL			3	1
073-100051-00X	21 7/8" END PANEL - SINGLE	ALL				2
173-100006-00X	16 5/8" UV END PANEL KIT W/HARDWARE	ALL				
173-100006-01X	21 7/8" UV END PANEL KIT W/HARDWARE	ALL				
373-100087-002	UV END PANEL FASTENER KIT	ALL		SD		

Note: Fastener kit includes bushing, bolt, & clip for mounting panels.

**VERTICAL UNITS - TOPS AND GRILLES**

Replace X With 1=Beige, 2=Polar Ice, 3=Bronze, 4=White, 6=Gray

Part Number	Description	Fits Series			Page #	ITEM #
373-280029-01X	TOP ONLY - NO GRILLE	UV-500 REV "D"			3	8
373-280009-01X	FALSE BACK TOP	UV-500				10
373-280029-02X	TOP ONLY - NO GRILLE	UV-750 REV "D"				8
373-280009-02X	FALSE BACK TOP	UV-750				10
373-280029-03X	TOP ONLY - NO GRILLE	UV-1000 REV "D"				8
373-280009-03X	FALSE BACK TOP	UV-1000				10
373-280029-04X	TOP ONLY - NO GRILLE	UV-1250 REV "D"				8
373-280009-04X	FALSE BACK TOP	UV-1250				10
373-280029-05X	TOP ONLY - NO GRILLE	UV-1500 REV "D"				8
373-280009-05X	FALSE BACK TOP	UV-1500				10

(17)

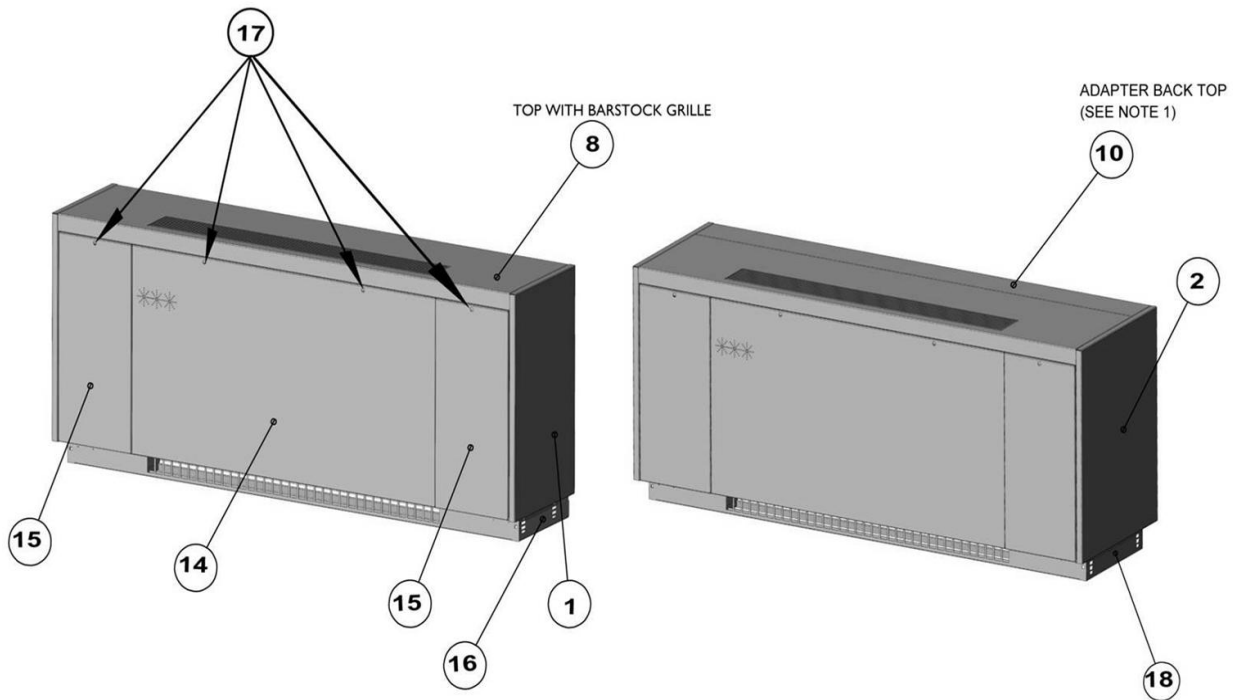

**HORIZONTAL UNITS - PANELS, TOPS, & GRILLES**

Replace X With 1=Beige, 2=Polar Ice, 3=Bronze, 4=White, 6=Gray

Part Number	Description	Fits Series			Page #	ITEM #
373-280120-02X	BLOWER ACCESS PANEL	UH-750			4	11
373-280120-03X	BLOWER ACCESS PANEL	UH-1000				
373-280120-04X	BLOWER ACCESS PANEL	UH-1250				
373-280120-05X	BLOWER ACCESS PANEL	UH-1500				
373-280016-02X	LOUVERED FILTER ACCESS PANEL	UH-750			4	12
373-280016-03X	LOUVERED FILTER ACCESS PANEL	UH-1000				
373-280016-04X	LOUVERED FILTER ACCESS PANEL	UH-1250				
373-280016-05X	LOUVERED FILTER ACCESS PANEL	UH-1500				
373-280015-02X	SOLID FILTER ACCESS PANEL	UH-750			4	13
373-280015-03X	SOLID FILTER ACCESS PANEL	UH-1000				
373-280015-04X	SOLID FILTER ACCESS PANEL	UH-1250				
373-280015-05X	SOLID FILTER ACCESS PANEL	UH-1500				
373-100068-01X	30.5" UH END PANEL KIT W/HARDWARE	UH				
373-100069-01X	36" UH END PANEL KIT W/HARDWARE	UH				
373-100070-01X	40" UH END PANEL KIT W/HARDWARE	UH				
Part Number	Description	Fits Series			Page #	ITEM #
373-280017-02X	FRONT DISCHARGE TOP	UH-750 REV "D"			4	6
373-280017-03X	FRONT DISCHARGE TOP	UH-1000 REV "D"				
373-280017-04X	FRONT DISCHARGE TOP	UH-1250 REV "D"				
373-280017-05X	FRONT DISCHARGE TOP	UH-1500 REV "D"				
373-280017-05X	FRONT DISCHARGE TOP	UH-2000 REV "D"				
373-280030-02X	BOTTOM DISCHARGE TOP	UH-750 REV "D"			4	7
373-280030-03X	BOTTOM DISCHARGE TOP	UH-1000 REV "D"				
373-280030-04X	BOTTOM DISCHARGE TOP	UH-1250 REV "D"				
373-280030-05X	BOTTOM DISCHARGE TOP	UH-1500 REV "D"				
373-280030-05X	BOTTOM DISCHARGE TOP	UH-2000 REV "D"				
UV0512	DOUBLE DEFLECTION GRILLE	UH-750			4	5
UV0515	DOUBLE DEFLECTION GRILLE	UH-1000				
UV0513	DOUBLE DEFLECTION GRILLE	UH-1250				
UV0514	DOUBLE DEFLECTION GRILLE	UH-1500				
UV0514	DOUBLE DEFLECTION GRILLE	UH-2000				

Note: Front or bottom discharge top does not include double deflection grille. Order grille separately

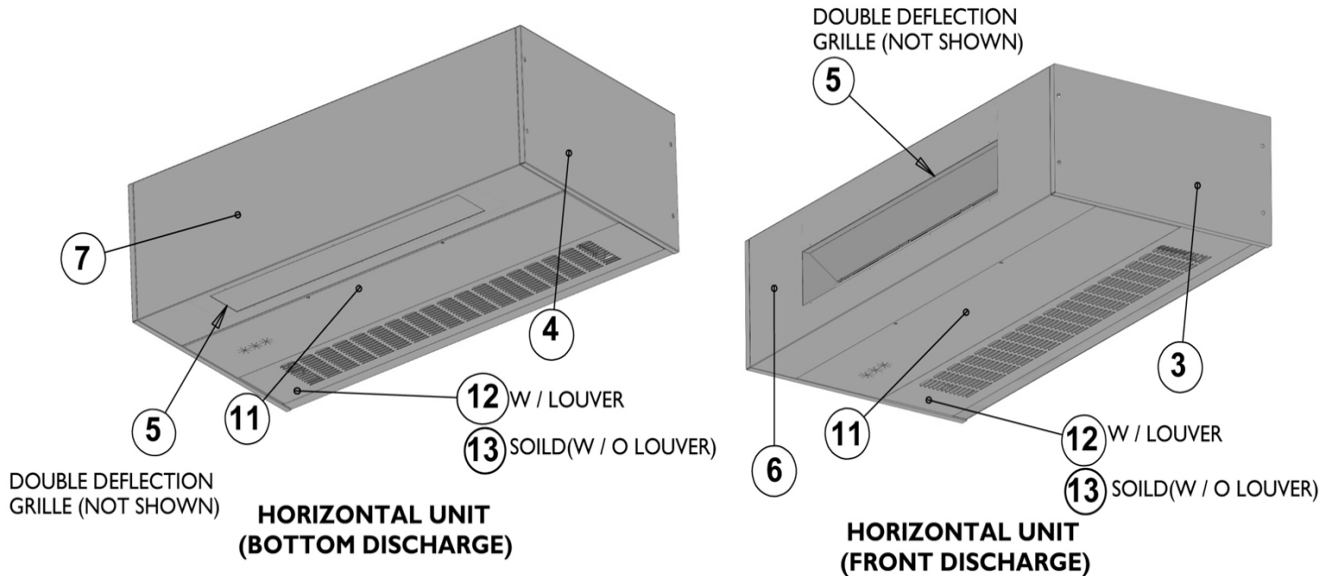

**COILS - CHILLED AND HOT WATER REV "A" THRU REV "D"**

Part Number	Description	Fits Series			Page #	ITEM #
494152	1 ROW CW/HW COIL	UV-500				
494162	1 ROW CW/HW COIL	UV/UH-750				
RP494172	1 ROW CW/HW COIL	UV/UH-1000				
RP494182	1 ROW CW/HW COIL	UV/UH-1250				
RP494192	1 ROW CW/HW COIL	UV/UH-1500				
RP494192	1 ROW CW/HW COIL	UH-2000				
RP494102	2 ROW CW/HW COIL	UV-500				
RP494112	2 ROW CW/HW COIL	UV/UH-750				
RP494122	2 ROW CW/HW COIL	UV/UH-1000				
RP494132	2 ROW CW/HW COIL	UV/UH-1250				
RP494142	2 ROW CW/HW COIL	UV/UH-1500				
RP494142	2 ROW CW/HW COIL	UH-2000				
494052	3 ROW CW/HW COIL	UV-500				
RP494062	3 ROW CW/HW COIL	UV/UH-750				
RP494072	3 ROW CW/HW COIL	UV/UH-1000				
RP494082	3 ROW CW/HW COIL	UV/UH-1250				
RP494092	3 ROW CW/HW COIL	UV/UH-1500				
RP494092	3 ROW CW/HW COIL	UH-2000				
RP494042	4 ROW CW/HW COIL	UV-500				
RP494002	4 ROW CW/HW COIL	UV/UH-750				
RP494012	4 ROW CW/HW COIL	UV/UH-1000				
RP494022	4 ROW CW/HW COIL	UV/UH-1250				
RP494032	4 ROW CW/HW COIL	UV/UH-1500				
RP494032	4 ROW CW/HW COIL	UH-2000				
RP494322	5 ROW CW/HW COIL	UV-500				
494302	5 ROW CW/HW COIL	UV/UH-750				
494332	5 ROW CW/HW COIL	UV/UH-1000				
RP494342	5 ROW CW/HW COIL	UV/UH-1250				
RP494312	5 ROW CW/HW COIL	UV/UH-1500				
RP494312	5 ROW CW/HW COIL	UH-2000				
UV0146	Water Coil Low Limit Stat - 38 Degf / 42 Degf	All			SD	5 1

**COILS - DX - Rev A-B-C-D**

Part Number	Description	Fits Series			Page #	ITEM #
494200	DX Coil - 3 Row	UV/UH-750				
494220	DX Coil - 3 Row	UV/UH-1000				
494240	DX Coil - 3 Row	UV/UH-1250				
494260	DX Coil - 3 Row	UV/UH-1500				
494260	DX Coil - 3 Row	UH-2000				
494000	DX Coil - 4 Row	UV/UH-750				
494010	DX Coil - 4 Row	UV/UH-1000				
494020	DX Coil - 4 Row	UV/UH-1250				
494030	DX Coil - 4 Row	UV/UH-1500				
494030	DX Coil - 4 Row	UH-2000				
702025	DX LOW LIMIT STAT - 28 DEG f	ALL			SD	5 2



**STEAM COILS**

Part Number	Description	Fits Series		Page #	ITEM #
102000	1 ROW LOW CAPACITY	UV-500	6 Weeks		
102001	1 ROW LOW CAPACITY	UV/UH-750	6 Weeks		
102002	1 ROW LOW CAPACITY	UV/UH-1000	6 Weeks		
102003	1 ROW LOW CAPACITY	UV/UH-1250	6 Weeks		
102004	1 ROW LOW CAPACITY	UV/UH-1500	6 Weeks		
102004	1 ROW LOW CAPACITY	UH-2000	6 Weeks		
102005	2 ROW HIGH CAPACITY	UV-500	6 Weeks		
102006	2 ROW HIGH CAPACITY	UV/UH-750	6 Weeks		
102007	2 ROW HIGH CAPACITY	UV/UH-1000	6 Weeks		
102008	2 ROW HIGH CAPACITY	UV/UH-1250	6 Weeks		
102009	2 ROW HIGH CAPACITY	UV/UH-1500	6 Weeks		
102009	2 ROW HIGH CAPACITY	UH-2000	6 Weeks		
102000-OPP	1 ROW LOW CAP. OPP END CONX	UV-500	6 Weeks		
102001-OPP	1 ROW LOW CAP. OPP END CONX	UV/UH-750	6 Weeks		
102002-OPP	1 ROW LOW CAP. OPP END CONX	UV/UH-1000	6 Weeks		
102003-OPP	1 ROW LOW CAP. OPP END CONX	UV/UH-1250	6 Weeks		
102004-OPP	1 ROW LOW CAP. OPP END CONX	UV/UH-1500	6 Weeks		
102004-OPP	1 ROW LOW CAP. OPP END CONX	UH-2000	6 Weeks		
102005-OPP	2 ROW HIGH CAP. OPP END CONNX	UV-500	6 Weeks		
102006-OPP	2 ROW HIGH CAP. OPP END CONNX	UV/UH-750	6 Weeks		
102007-OPP	2 ROW HIGH CAP. OPP END CONNX	UV/UH-1000	6 Weeks		
102008-OPP	2 ROW HIGH CAP. OPP END CONNX	UV/UH-1250	6 Weeks		
102009-OPP	2 ROW HIGH CAP. OPP END CONNX	UV/UH-1500	6 Weeks		
102009-OPP	2 ROW HIGH CAP. OPP END CONNX	UH-2000	6 Weeks		
594725	VACUUM BREAKER ASSY	ALL		6	1

Note 1: Vacuum breaker assy required, one each per steam coil. Mechanically connects to coil manifold with 1/4" MPT x 1/2" factory provided adapter

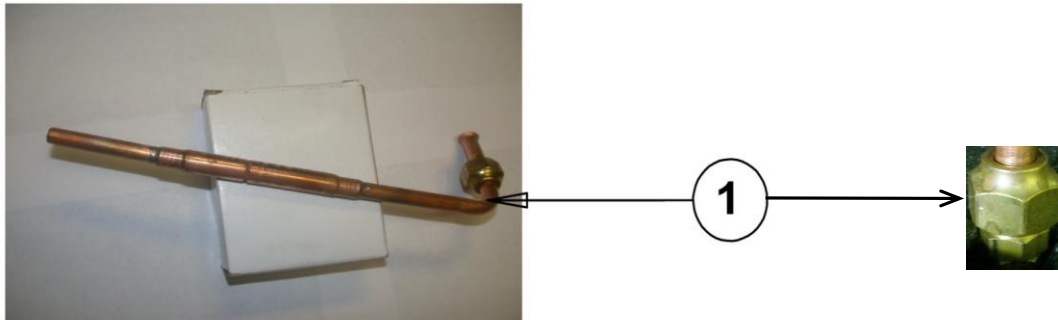

**DRAINPANS**

Part Number	Description	Fits Series			Page #	ITEM #
594522	Drainpan for unit w/face-&-bypass	UH-750 Rev A/B/C				
594523	Drainpan for unit w/face-&-bypass	UH-1000 Rev A/B/C				
594524	Drainpan for unit w/face-&-bypass	UH-1250 Rev A/B/C				
594525	Drainpan for unit w/face-&-bypass	UH-1500 Rev A/B/C				
594525	Drainpan for unit w/face-&-bypass	UH-2000 Rev A/B/C				
596015	Drainpan for unit w/o face-&-bypass	UH-750 Rev A/B/C				
596014	Drainpan for unit w/o face-&-bypass	UH-1000 Rev A/B/C				
596013	Drainpan for unit w/o face-&-bypass	UH-1250 Rev A/B/C				
596000	Drainpan for unit w/o face-&-bypass	UH-1500 Rev A/B/C				
596000	Drainpan for unit w/o face-&-bypass	UH-2000 Rev A/B/C				
594516	Drainpan for Vert Unit	UV-500 Rev A/B/C				
594517	Drainpan for Vert Unit	UV-750 Rev A/B/C				
594518	Drainpan for Vert Unit	UV-1000 Rev A/B/C				
594519	Drainpan for Vert Unit	UV-1250 Rev A/B/C				
594520	Drainpan for Vert Unit	UV-1500 Rev A/B/C				
073-102161-001	Drainpan for Horz. Unit	UH-750 Rev D/E				
073-103161-001	Drainpan for Horz. Unit	UH-1000 Rev D/E				
073-104161-001	Drainpan for Horz. Unit	UH-1250 Rev D/E				
073-105161-001	Drainpan for Horz. Unit	UH-1500 Rev D/E				
073-105161-001	Drainpan for Horz. Unit	UH-2000 Rev D/E				
073-101151-001	Drainpan for Vert Unit	UV-500 Rev D/E/F				
073-102151-001	Drainpan for Vert Unit	UV-750 Rev D/E/F				
073-103151-001	Drainpan for Vert Unit	UV-1000 Rev D/E/F				
073-104151-001	Drainpan for Vert Unit	UV-1250 Rev D/E/F				
073-105151-001	Drainpan for Vert Unit	UV-1500 Rev D/E/F				

BLOWER SHAFTS, WHEELS, BEARINGS						
Part Number	Description	Fits Series			Page #	ITEM #
UV0202	BLOWER SHAFT PRIOR TO 07-2002	UV-500				
UV0202	BLOWER SHAFT PRIOR TO 07-2002	UV/UH-750				
UV0203	BLOWER SHAFT PRIOR TO 07-2002	UV/UH-1000				
UV0147	BLOWER SHAFT PRIOR TO 07-2002	UV/UH-1250				
UV0204	BLOWER SHAFT PRIOR TO 07-2002	UV/UH-1500				
UV0204	BLOWER SHAFT PRIOR TO 07-2002	UH-2000				
UV0560	BLOWER SHAFT AFTER 07-2002	UV-500				
UV0561	BLOWER SHAFT AFTER 07-2002	UV/UH-750				
UV0562	BLOWER SHAFT AFTER 07-2002	UV/UH-1000				
UV0563	BLOWER SHAFT AFTER 07-2002	UV/UH-1250				
UV0564	BLOWER SHAFT AFTER 07-2002	UV/UH-1500				
UV0564	BLOWER SHAFT AFTER 07-2002	UH-2000				
UV0196	COUPLING - MOTOR to SHAFT	ALL		SD	8	7
UV0149	BLOWER WHEEL - Up to Rev D	UV/UH - Rev A-D		SD		
594513	SLEEVE BEARING BRACKET	All				8
UV0799	BLOWER WHEEL	UH-2000		SD		
UV0188	SLEEVE BEARING - End of Shaft	All		SD	8	11
103099	Ball Bearing - Middle	All		SD	8	21

**MOTORS**

Include Serial Number with Order for ECM Motors

Part Number	Description	Fits Series			Page #	ITEM #
RUV0145	PSC MOTOR 1/8 HP (Note 3)	Rev A, B, C		SD	8	1
102902	PSC MOTOR 1/4 HP (Note 3)	Rev D		SD		1
112038	PSC MOTOR MOUNTING RING	ALL		SD		3
UV0177	ECM MOTOR 1/3 HP 120V/240V/480V (Notes 1,2,4)	UV/UH-500-1000		SD	8	20
UV0178	ECM MOTOR 1/2 HP 120V/240V/480V (Notes 1,2,4)	UV/UH-1250/1500		SD		
UV0179	ECM MOTOR 3/4 HP 120V/240V/480V (Notes 1,2,4)	UH-2000		SD		
UV0182	ECM MOTOR 1/3 HP 277V (Notes 1,2,4)	UV/UH-500-1000		SD		
UV0183	ECM MOTOR 1/2 HP 277V (Notes 1,2,4)	UV/UH-1250/1500		SD		
UV0181	ECM MOTOR 3/4 HP 277V (Notes 1,2,4)	UH-2000		SD		
173-280026-001	ECM MOTOR SHROUD KIT 1/3HP					
173-280026-002	ECM MOTOR SHROUD KIT 1/2HP					
173-280026-003	ECM MOTOR SHROUD KIT 3/4HP	UH-2000				

Note1: ECM motor requires shroud to be in place to avoid overheating and premature failure.

Note2: ECM motor requires factory programming. Provide unit serial number and program name from sticker on cap end of motor. See # 16 on page 9

Note3: PSC Motor and Capacitor sold as one assembly. Not sold separately. See #2 on page 8.

Note 4: ECM Motor and integrated control module sold as one assembly. Not sold separately. See #20 on page 8.

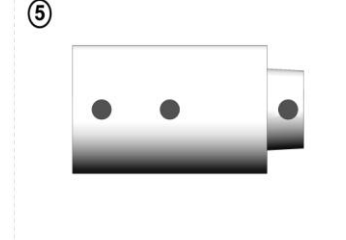
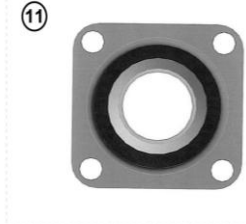
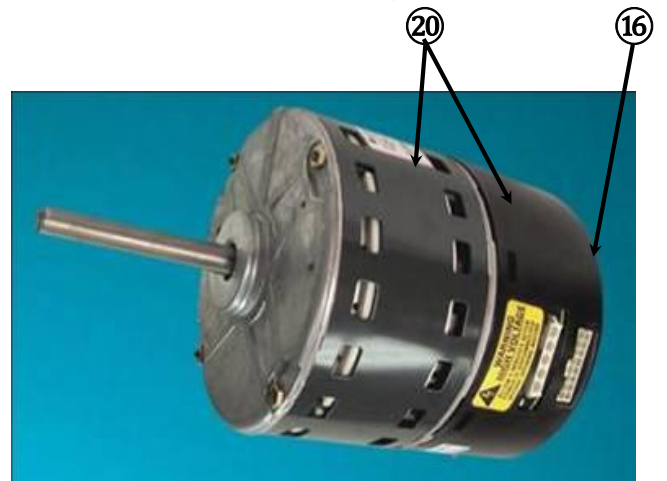
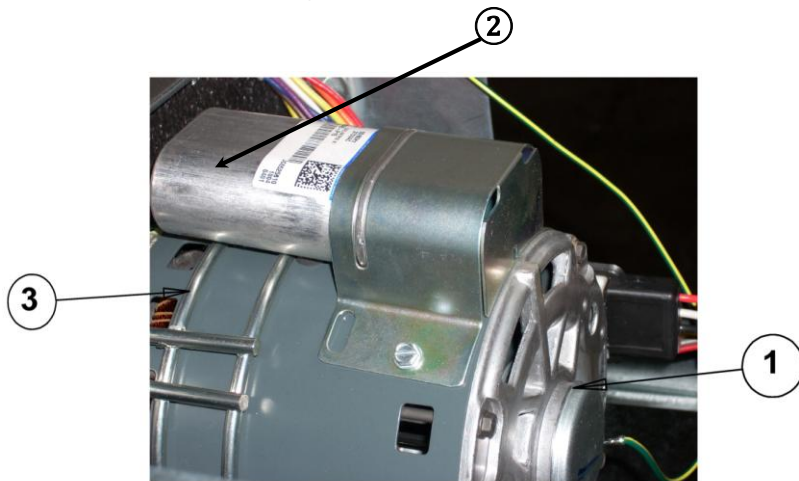

**MOTOR AND CONTROL ECM HARNESS**

Part Number	Description	Fits Series	List Price	Page #	ITEM #
037-00241	MLHARN ECM CNTRL			9	1
037-00250	ECM PWR HARNESS	UV 115 & 480V		9	2
037-00251	ECM PWR HARNESS	UV 208-277V		9	3

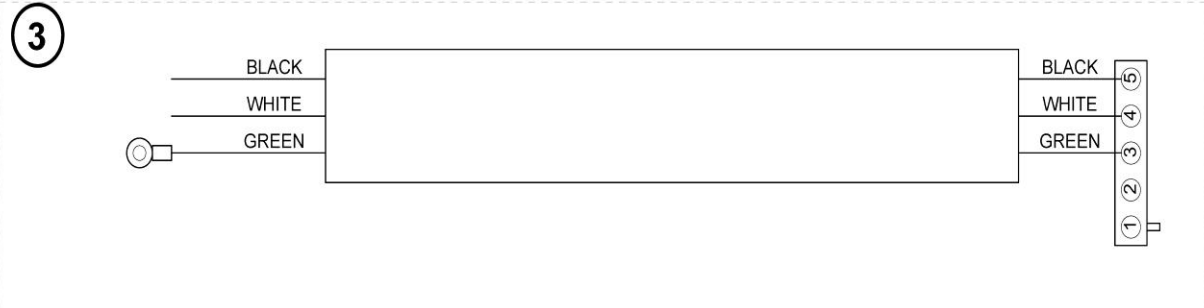
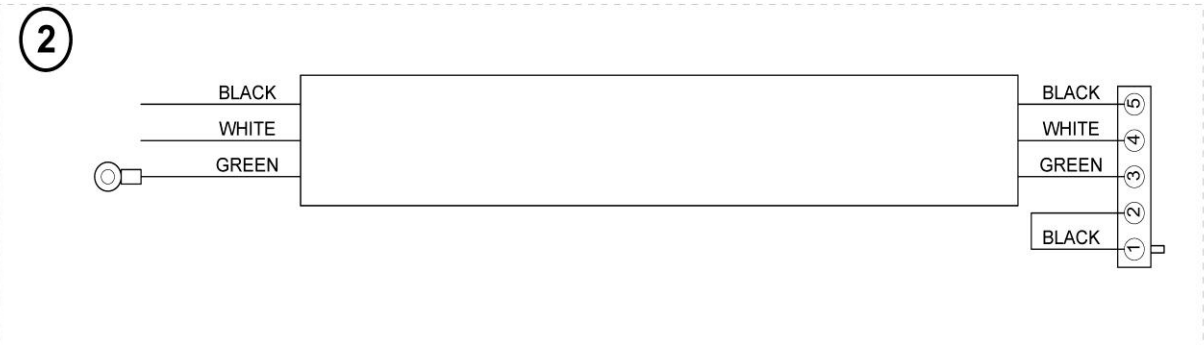
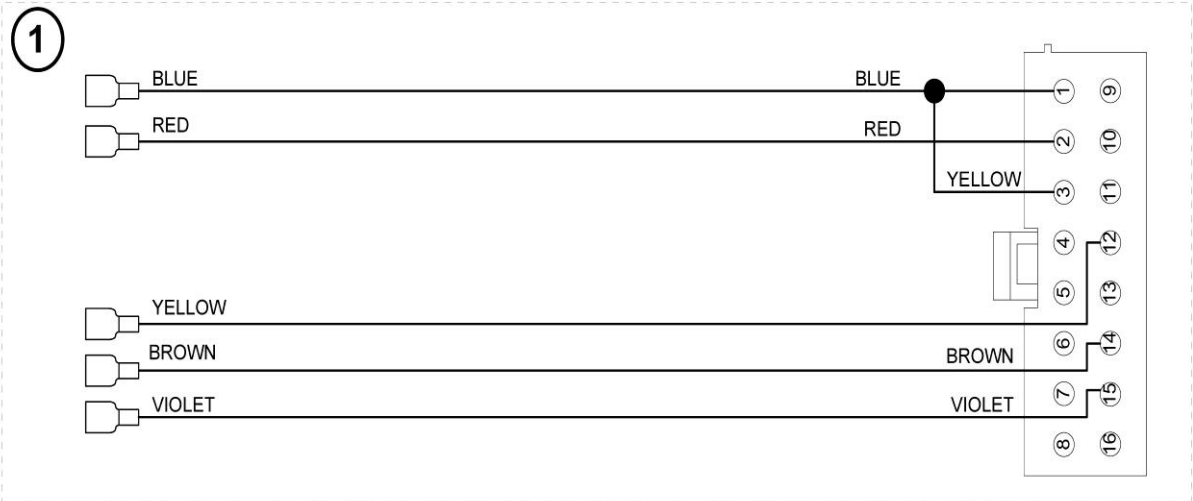

**FILTERS & TOUCH UP PAINT**

Part Number	Description	Fits Series	List Price		Page #	ITEM #
UV0335	THROWAWAY FILTER	UV-500		SD		
UV0165	THROWAWAY FILTER	UV/UH-750		SD		
UV0206	THROWAWAY FILTER	UV/UH-1000		SD		
UV0207	THROWAWAY FILTER	UV/UH-1250		SD		
UV0208	THROWAWAY FILTER	UV/UH-1500		SD		
UV0208	THROWAWAY FILTER	UH-2000		SD		
UV0297	PERMANENT FILTER	UV-500				
UV0298	PERMANENT FILTER	UV/UH-750				
UV0299	PERMANENT FILTER	UV/UH-1000				
UV0293	PERMANENT FILTER	UV/UH-1250				
UV0295	PERMANENT FILTER	UV/UH-1500				
UV0295	PERMANENT FILTER	UH-2000				
373-600002-001	RENEWABLE MEDIA FILTER	UV-500				
373-600002-002	RENEWABLE MEDIA FILTER	UV/UH-750				
373-600002-003	RENEWABLE MEDIA FILTER	UV/UH-1000				
373-600002-004	RENEWABLE MEDIA FILTER	UV/UH-1250				
373-600002-005	RENEWABLE MEDIA FILTER	UV/UH-1500				
373-600002-005	RENEWABLE MEDIA FILTER	UH-2000				
708316	12oz SPRAY CAN TOUCH UP POLAR ICE	Note 1		SD		
708310	12oz SPRAY CAN TOUCH UP BEIGE	Note 1		SD		
708321	12oz SPRAY CAN TOUCH UP GRAY	Note 1		SD		
708311	12oz SPRAY CAN TOUCH UP BRONZE	Note 1		SD		
708322	12oz SPRAY CAN TOUCH UP WHITE	Note 1		SD		

Note 1: Paint can only ship by ground.

**TRANSFORMERS**

Part Number	Description	Fits Series	List Price	Page #	ITEM #	
<b>PSC MOTOR TRANSFORMER</b>						
UV0125	1/8 HP 120V			11	3	
UV0998	1/4 HP 120V					
UV0123	1/8HP 208/230/277V					
UV0997	1/4 HP 208/230/277V					
<b>STEP DOWN MOTOR TRANSFORMER</b>						
UV0238	480V-120V MOTOR					
117031	277V-240V MOTOR					
<b>CONTROL TRANSFORMER</b>						
106543	120v - 24v 75va			11	4	
HT01BD203	208/230v - 24v 75va					
106544	277v - 24v 75va					
112003	120v - 24v 40va					
112158	208/230v - 24v 40va					
106986	277v - 24v 40va					
UV0377	480/277/208v - 24v 75va	<b>OBSOLETE PART</b>				
<b>CONTROL BOX COMPONENTS</b>						
UV0114	Blower Rocker Switch ON-OFF	ALL		SD	11	5
106777	Blower Toggle Switch HIGH-MED-LOW	ALL		SD	11	7
UV0110	Blower Speed Switch HI-LO-OFF	ALL		SD	11	7
UV0133	ECM SPEED SELECT BOARD	ALL		SD	11	11

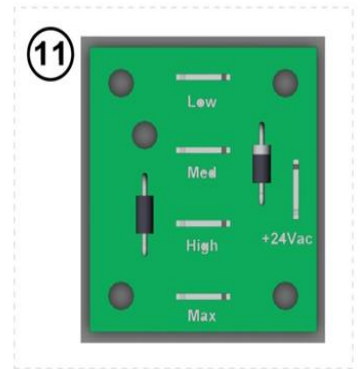
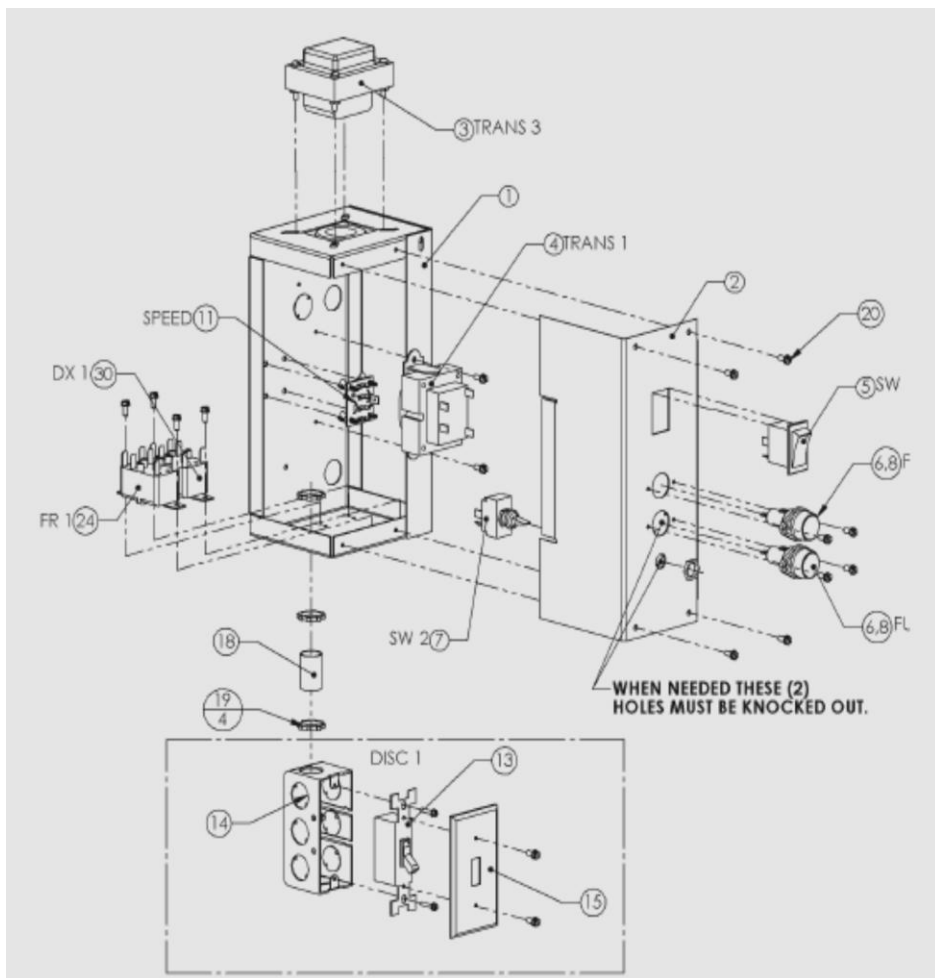

40

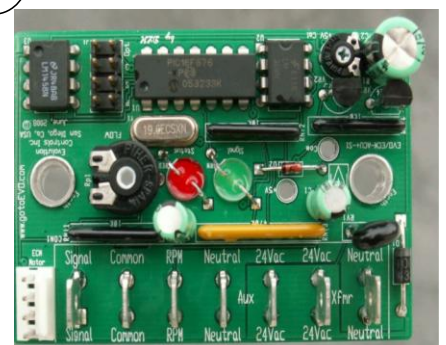

**ELECTRIC HEAT COMPONENTS**

Part Number	Description	Fits Series	List Price		Page #	ITEM #
117010	1.4 KW 208 VAC HEAT STRIP	UV-500		4 Weeks		
117009	1.4 KW 240 VAC HEAT STRIP	UV-500		4 Weeks		
117043	1.4 KW 277 VAC HEAT STRIP	UV-500		4 Weeks		
117044	1.4 KW 480 VAC HEAT STRIP	UV-500		4 Weeks		
117046	2.0 KW 208 VAC HEAT STRIP	UV/UH-750		4 Weeks		
117023	2.0 KW 240 VAC HEAT STRIP	UV/UH-750		4 Weeks		
117047	2.0 KW 277 VAC HEAT STRIP	UV/UH-750		4 Weeks		
117048	2.0 KW 480 VAC HEAT STRIP	UV/UH-750		4 Weeks		
117032	2.6 KW 208 VAC HEAT STRIP	UV/UH-1000		4 Weeks		
117024	2.6 KW 240 VAC HEAT STRIP	UV/UH-1000		4 Weeks		
117050	2.6 KW 277 VAC HEAT STRIP	UV/UH-1000		4 Weeks		
117051	2.6 KW 480 VAC HEAT STRIP	UV/UH-1000		4 Weeks		
117025	3.3 KW 208 VAC HEAT STRIP	UV/UH-1250		4 Weeks		
117022	3.3 KW 240 VAC HEAT STRIP	UV/UH-1250		4 Weeks		
117053	3.3 KW 277 VAC HEAT STRIP	UV/UH-1250		4 Weeks		
117054	3.3 KW 480 VAC HEAT STRIP	UV/UH-1250		4 Weeks		
117056	4.0 KW 208 VAC HEAT STRIP	UV/UH-1500/2000		4 Weeks		
117026	4.0 KW 240 VAC HEAT STRIP	UV/UH-1500/2000		4 Weeks		
117057	4.0 KW 277 VAC HEAT STRIP	UV/UH-1500/2000		4 Weeks		
117058	4.0 KW 480 VAC HEAT STRIP	UV/UH-1500/2000		4 Weeks		
117039	MANUAL HIGH LIMIT T-STAT 220	REV - A - B - C - D				
117038	AUTO HIGH LIMIT T-STAT 165	REV - A - B - C - D				
112325	BROWNOUT PROTECTOR	ALL				
010-171000-000	ELECTRIC HEAT RELAY	ALL				
HY12FU030	FUSE HOLDER	ALL		SD		
112381	FUSE 3.5 AMP	ALL				
112384	FUSE 4.0 AMP	ALL				
HY10QR050	FUSE 5.0 AMP	ALL				
106188	FUSE 6.0 AMP	ALL				
112374	FUSE 10 AMP	ALL				
112377	FUSE 15 AMP	ALL				
106992	FUSE BLOCK - ELECTRIC HEAT	ALL				
112378	FUSE 20 AMP	ALL				
106990	FUSE 35 AMP	ALL				
106652	FUSE 30 AMP	ALL				
106653	FUSE 40 AMP	ALL				
106657	FUSE 45 AMP	ALL				
106654	FUSE 50 AMP	ALL				
106655	FUSE 60 AMP	ALL				

**CONTROLS**

Part Number	Description	Fits Series	List Price		Page #	ITEM #
UV0391	MNL20RXX CONTROLLER (NOTE 1)	ALL		SD	13	1
UV0401	O/A, R/A, S/A Temp Sensor	ALL		SD	13	5
UV0395	MN-S4 STAT	ALL		SD		2
UV0427	JUMPER COMB	ALL		SD		
UV0361	CURRENT SENSING	ALL		SD		
103456	F/B Damper Actuator (Belimo, 4-20)	ALL		SD	13	6
103455	O/A Damper Actuator (Belimo, 4-20)	ALL		SD		7
103458	F/B Damper Actuator (Belimo, 0-10)	ALL		SD		6
103457	O/A Damper Actuator (Belimo, 0-10)	ALL		SD		7
117075	7/8 OD Changeover (Aqua) Sensor	See Note 2				

Note 1: MNLController must be factory programmed.

Provide unit model no., serial no., and program name form controller label. See #4 and 1.

Note 2: Changeover sensor must be clamped onto the pipe supplying water to the unit upstream of the valve. See unit IOM.

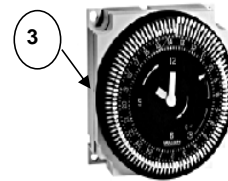

2

1

4

3

5

6

7

6

**WATER VALVES & ACTUATORS**

Part Number	Description	Fits Series	List Price	SHIP	PAGE #	ITEM
100896	2-WAY ERIE VALVE VT2313	ALL			14	1
100899	2-WAY ERIE VALVE VM2313	ALL			14	1
100898	2-WAY ERIE VALVE VM2312	ALL			14	1
100894	2-WAY ERIE VALVE VM2517	ALL			14	1
100897	3-WAY ERIE VALVE VT3315	ALL			14	1
100907	3-WAY ERIE VALVE VM3313	ALL			14	1
100903	3-WAY ERIE VALVE VM3312	ALL			14	1
100895	3-WAY ERIE VALVE VM3517	ALL			14	1
011-999999-001	3-WAY ERIE VALVE VM2323	ALL			14	1
100909	VALVE ACTUATORS - ERIE AH23A020	ALL			14	2
100916	VALVE ACTUATORS - ERIE AH13A020	ALL			14	2
100919	VALVE ACTUATORS - ERIE AG24A020	ALL			14	2
100920	VALVE ACTUATORS - ERIE AG13A020	ALL			14	2
100922	VALVE ACTUATORS - ERIE AT13A000	ALL			14	3
100922	VALVE ACTUATORS - ERIE AT13A00T	ALL			14	3
100923	VALVE ACTUATORS - ERIE AP13A000	ALL			14	3
100924	VALVE ACTUATORS - ERIE AP23A000	ALL			14	3
100925	2-WAY SIEMENS VALVE 599-01123	ALL			14	7
100929	2-WAY SIEMENS VALVE 599-01108	ALL			14	7
100926	2-WAY SIEMENS VALVE 599-01126	ALL			14	7
100930	2-WAY SIEMENS VALVE 599-01110	ALL			14	7
100931	2-WAY SIEMENS VALVE 599-01129	ALL			14	7
100927	3-WAY SIEMENS VALVE 599-01123	ALL			14	6
100935	3-WAY SIEMENS VALVE 599-01137	ALL			14	6
100936	3-WAY SIEMENS VALVE 599-01138	ALL			14	6
100937	3-WAY SIEMENS VALVE 599-01139	ALL			14	6
011-800000-000	VALVE ACTUATOR - SIEMENS SSC81.5U	ALL			14	5
100938	VALVE ACTUATOR - SIEMENS SSC61.5U	ALL			14	5
UV0434	VALVE UNION				14	8
700073	BALL VALVE - 3/4"					
700154	CIRCUIT SETTER - 3/4"				14	11
706061	BALL VALVE - W/MEMORY INDICATOR				14	9
700077	Y STRAINER - 3/4"				14	10
UV0489	1/2 NPT BRASS PLUG					



1



2



3



4

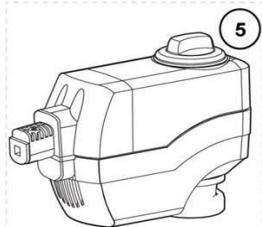

5

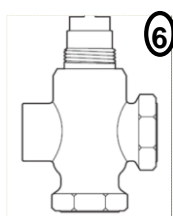

6

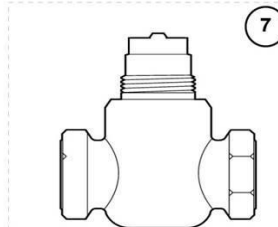

7

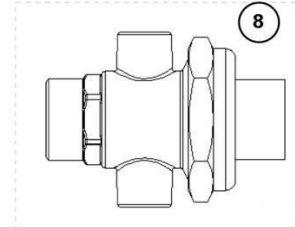

8



9



10



11

## Freight Zone Map - Cost Adders



<b>Standard Delivery</b>	<b>Zone 1: Add 2.5% of List Price</b>	<b>Zone 3: Add 3.6% of List Price</b>
	<b>Zone 2: Add 3.5% of List Price</b>	<b>Zone 4: Add 3.8% of List Price</b>
	<b>Zone 5: Add 5.0% of List Price</b>	<b>Zone 6: Add 6.0% of List Price</b>

Canada Minimum freight charge of \$125  
 Zone 5 Covers: Quebec, British Columbia, and Lower Ontario  
 Zone 6 Covers: Alberta, Saskatchewan, and Manitoba

<b>2-Day Expedite</b>	<b>Zone 1: Add 8.5% of List Price</b>	<b>Zone 3: Add 11% of List Price</b>
	<b>Zone 2: Add 10% of List Price</b>	<b>Zone 4: Add 12% of List Price</b>
	<b>Zone 5: Add 12% of List Price - US Only</b>	