



"HINGE" ROOF CURB
MODEL 010-225000-024 / 010-225000-048 /
010-225000-090

This Roof Curb is NRCA approved and is constructed of 18 gauge galvanized steel with a full perimeter 2" x 4" wood nailer strip. The curb is shipped with the following parts, as shown in Figure 2:

- 2 ea. Curb Short Sides (A)
- 2 ea. Curb Long Sides (B)
- 2 ea. Horizontal Duct Support (C)
- 2 ea. Vertical Duct Support (D)
- 1 ea. Hardware Package Includes:
 - 4 ea. "Hinge" Pins
 - 8 ea. Hex Washers screws #10 x 1/2"
 - 2 ea. Gasket 3/4" x 1 1/4" x 14' (28 ft. total)

DIMENSIONS	
MODEL#	HEIGHT
010-225000-024	14
010-225000-048	14
010-225000-090	14

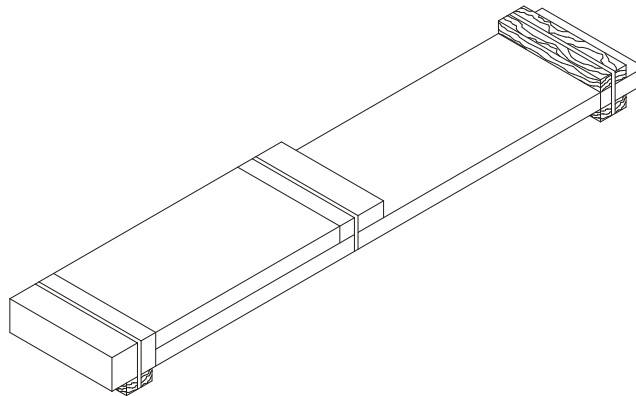

Figure 1

Step 1:

Curb Package is shown as shipped with easy to identify part numbers on all sides. Cut shipping bands and remove Hardware, Gasketing, and 4 Duct Supports.

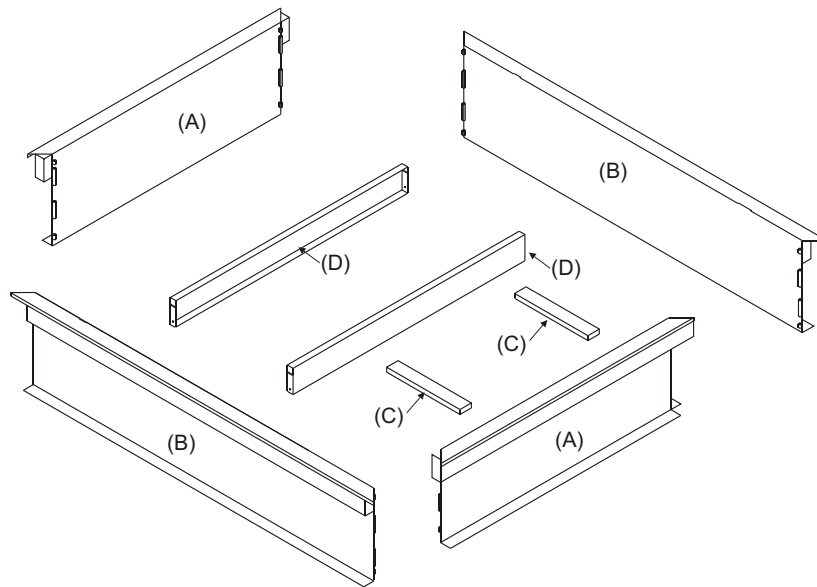

Figure 2

Step 2:

Layout the curb pieces before assembly to insure that all the necessary pieces are included.

U.S. PATENT 5148647

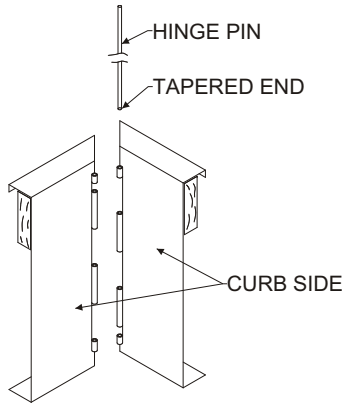

Figure 3

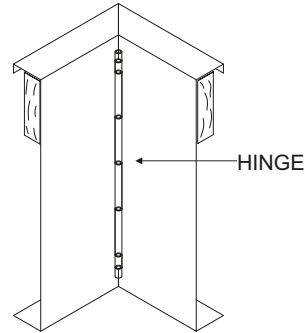

Figure 4

Step 3:

Corner Assembly: Align each curb side as shown in Figure 3. Using a hammer, drive the curb "hinge" pin down until the top of the pin is below the top of the curb as shown in Figure 4.

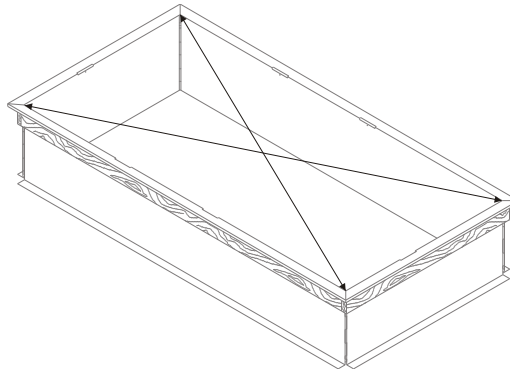

Figure 5

Step 4:

After the four corners are assembled; the curb should be checked to be sure it is in "square". Do this by measuring diagonally from each opposite corner as shown in Figure 5. The two measurements should be the same for each direction.

DETAILS

1.

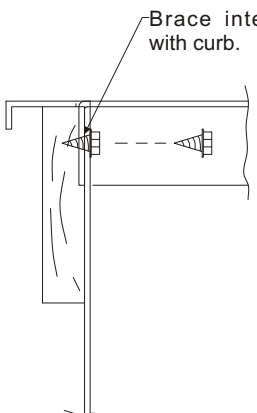

Brace interlocks with curb.

Duct Support flange goes in slot on curb. Screw Brace to curb.

2.

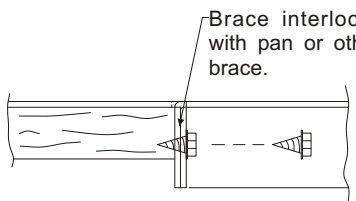

Brace interlocks with pan or other brace.

Duct Support flange goes in slot on pan or other brace. Screw brace together.

3.

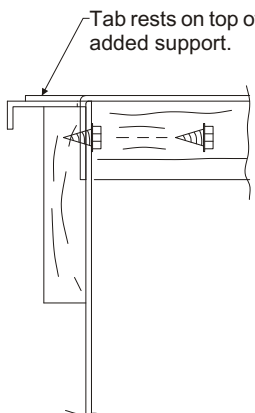

Tab rests on top of curb for added support.

Duct Support is supported by "tabs". Screw pan to curb.

Note:

Duct Supports can be located on either end depending on individual applications.

Step 5:

Install the vertical duct supports (D) as shown in Figure 6 with opening over the desired duct location.

Step 6:

Install the horizontal duct supports (C) as shown in Figure 6.

Step 7:

If the curb is being assembled and moved to another location, attach the duct supports as shown in "Details".

Step 8:

Place the 3/4" x 1 1/4" Gasket on all of the top edges of the Roof Curb, including the duct supports.

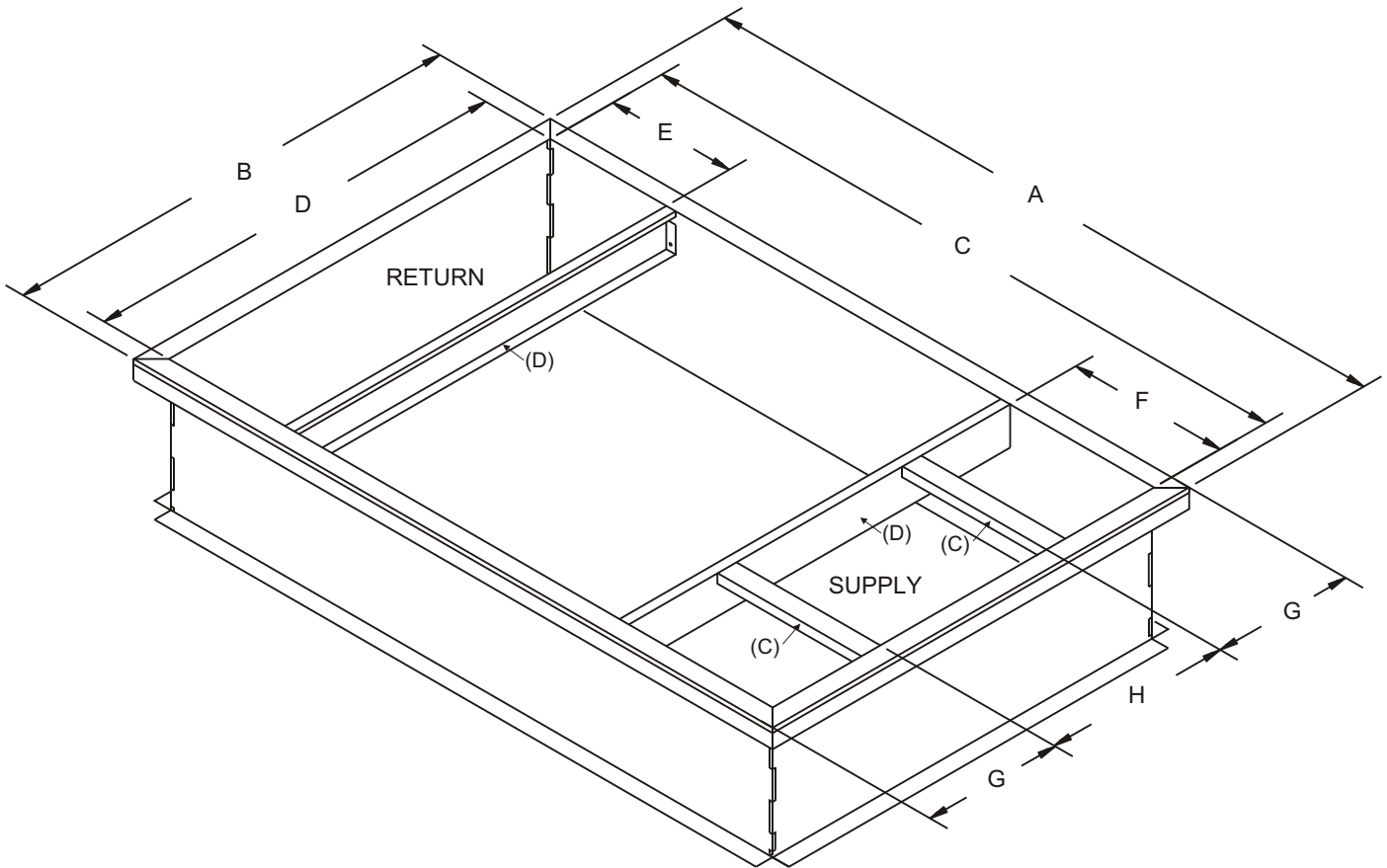

Figure 6

MODEL#	A	B	C	D	E	F	G	H	ROOF OPENING	DUCT SIZE	
										SUPPLY	RETURN
010-225000-024	63 7/8	36	60 1/8	32 1/4	12 5/8	13 1/4	7 3/8	21 1/4	32 1/4 x 60 7/8	12 3/4 x 20 3/4	12 1/8 x 31 3/4
010-225000-048	68 1/4	44 1/2	64 1/2	40 3/4	12 5/8	17 3/8	11 5/8	21 1/4	40 3/4 x 64 1/2	16 7/8 x 20 3/4	12 1/8 x 40 1/4
010-225000-090	71 1/2	49 1/2	67 3/4	45 3/4	15 1/2	17 3/4	7 3/8	34 3/4	45 3/4 x 49 1/2	17 1/4 x 34 1/4	15 x 45 1/2

ROOF INSTRUCTIONS

