

**FRONT COVER**

Decorative, slim cabinet designed for exposed floor mounted applications. Unit includes louvered discharge grille. Cabinet is galvanealed steel with baked powder coating for the ultimate in durability. All panels are lined with acoustic and thermal glass fiber insulation. Filters are one inch throwaway and are accessed through the bottom service panel. Optional mixed air damper for 100% outside air requirements.

### Product Description

#### MODEL NUMBER IDENTIFICATION

030 CFW 31

MODEL BTU CAPACITY \_\_\_\_\_

CABINET (F=FLAT TOP; S=SLOPE TOP)  
& COIL STYLE (W=WATER) \_\_\_\_\_

COIL ROWS \_\_\_\_\_

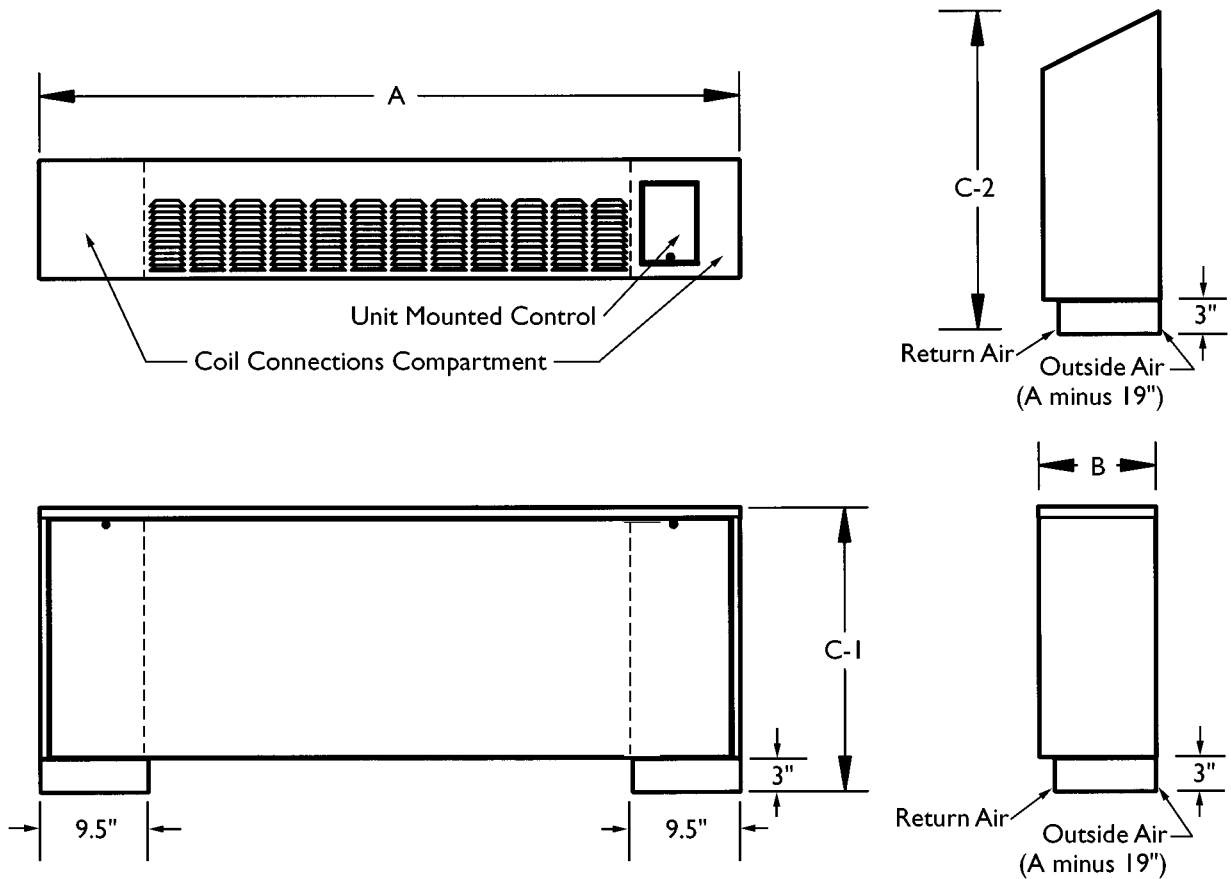

MODEL #	OVERALL WIDTH A	OVERALL DEPTH B	OVERALL HEIGHT C-1	OVERALL HEIGHT C-2	FILTER	COOLING COIL CONN.	HEATING COIL CONN.	UNIT WEIGHT
006-CFW-A	40.00	10.25	25.00	28.00	10X18X1	5/8" OD	5/8" OD	55
012-CFW-A	43.00	10.25	25.00	28.00	10X21X1	5/8" OD	5/8" OD	59
018-CFW-A	52.00	10.25	25.00	28.00	10X33X1	5/8" OD	5/8" OD	77
024-CFW-A	61.00	10.25	25.00	28.00	10X42X1	5/8" OD	5/8" OD	87
030-CFW-A	70.00	10.25	25.00	28.00	10X51X1	5/8" OD	5/8" OD	105
036-CFW-A	79.00	10.25	25.00	28.00	10X60X1	5/8" OD	5/8" OD	150



## CF\* Series Electrical Data

Model #	KW Heat 120 208 240	Miniumum Circuit Ampacity @ 120 VAC	Maximum Fuse Size @ 120 VAC	Miniumum Circuit Ampacity @ 208 VAC	Maximum Fuse Size @ 208VAC	Miniumum Circuit Ampacity @ 240 VAC	Maximum Fuse Size @ 240VAC
<b>006</b>	0	0.5	15	0.4	15	0.4	15
006-1.0E	1.0	11.0	15	6.5	15	5.70	15
006-1.5E	1.5	16.1	20.0	9.5	15	8.3	15
<b>012</b>	0	1.1	15	0.5	15	0.5	15
012-1.0E	1.0	11.5	15	6.6	15	5.8	15
012-1.5E	1.5	16.7	20.0	9.6	15	8.4	15
012-2.0E	2.0	21.9	25.0	12.6	15	11.1	15
<b>018</b>	0	1.8	15	0.6	15	0.60	15
018-1.0E	1.0	12.2	15	6.8	15	6.0	15
018-1.5E	1.5	17.4	20	9.8	15	8.6	15
018-2.0E	2.0	22.6	25	12.8	15	11.2	15
018-3.0E	3.0	33.0	35	18.8	25	16.4	20.0
018-4.0E	4.0	43.4	45	24.8	30	21.6	25.0
<b>024</b>	0	1.0	15	0.8	15	0.80	15
024-2.0E	2.0	22.1	25	13.0	20	11.4	15
024-3.0E	3.0	32.5	35	19.0	25	16.6	20
024-4.0E	4.0	43.0	50	25.0	30	21.8	25.0
<b>030</b>	0	1.8	15	0.9	15	0.9	15
030-3.0E	3.0	33.5	35	19.1	25	16.8	20
030-4.0E	4.0	43.9	45	25.1	30	22.0	25
030-5.0E	5.0	54.3	60	31.1	35	27.2	30
<b>036</b>	0	2.8	15	1.2	15	1.2	15
036-3.0E	3.0	34.7	40	19.5	25	17.1	20
036-4.0E	4.0	45.2	50	25.5	30	22.3	25
036-5.0E	5.0	–	–	31.5	35	27.5	30
036-6.0E	6.0	–	–	37.5	45	32.8	35

MOTOR FLA			
MODEL	120V	208V	240V
<b>006</b>	0.5	0.40	0.40
<b>012</b>	1.1	0.50	0.50
<b>018</b>	1.8	0.60	0.60
<b>024</b>	1.0	0.80	0.80
<b>030</b>	1.8	0.90	0.90
<b>036</b>	2.8	1.20	1.20

## C\*W Blower Performance with 3 Row Coil

MODEL	CFM VS EXTERNAL STATIC PRESSURES (DRY COIL DATA SHOWN)				
	0.10	0.15	0.20	0.25	0.30
006	265	235	210	165	125
012	410	380	350	310	260
018	595	550	500	430	350
024	840	785	730	665	575
030	905	840	750	675	580
036	1190	1100	1000	860	700

## C\*W Blower Performance with 4 Row Coil

MODEL	CFM VS EXTERNAL STATIC PRESSURES (DRY COIL DATA SHOWN)				
	0.10	0.15	0.20	0.25	0.30
006	255	225	190	155	120
012	385	360	325	280	235
018	565	530	460	395	320
024	800	745	680	610	535
030	850	785	705	635	550
036	1130	1060	920	790	640

## C\*W Blower Performance with 5 Row Coil

MODEL	CFM VS EXTERNAL STATIC PRESSURES (DRY COIL DATA SHOWN)				
	0.10	0.15	0.20	0.25	0.30
006	240	210	180	150	110
012	370	335	300	260	220
018	530	480	425	355	300
024	750	700	630	565	500
030	800	735	660	600	510
036	1060	960	850	710	600

BLOWER CORRECTION FACTOR		
	MED	LOW
006	.90	.80
012	.90	.80
018	.95	.91
024	.95	.91
030	.90	.80
036	.95	.91

To get airflow data at medium and low speeds, multiply blower performance by correction factor.

## C\*W-3 Coil Capacities

Ent Wtr	GPM	PD FT.	CFM	85 degF DB/71 deg.F WB				LWT Deg F	80 deg.F DB/67 degF WB				LWT Deg F	75 degF DB/63 deg.F WB				LWT Deg F
				TTL MBH	SENS MBH	LVG DB	AIR WB		TTL MBH	SENS MBH	LVG DB	AIR WB		TTL MBH	SENS MBH	LVG DB	AIR WB	
006-C*W-3	1.0	1.83	100	5.2	3.2	55.6	54.9	55.5	4.2	2.8	53.7	53.0	53.5	3.3	2.5	51.9	51.2	51.7
			200	7.3	5.0	61.6	60.2	59.8	6.1	4.6	58.7	57.3	57.3	4.9	4.1	55.8	54.6	54.9
			300	8.5	6.5	64.7	62.8	62.3	7.2	6.0	61.3	59.5	59.5	5.9	5.5	58.0	56.4	56.9
	1.4	2.90	100	5.6	3.3	54.0	53.3	53.1	4.5	3.0	52.4	51.7	51.6	3.6	2.6	50.9	50.3	50.2
			200	8.4	5.4	59.8	58.5	57.1	6.9	4.9	57.2	55.9	54.9	5.5	4.3	54.8	53.5	52.9
			300	9.9	7.0	63.2	61.4	59.3	8.2	6.4	60.1	58.3	56.9	6.7	5.8	57.1	55.4	54.6
	1.9	4.60	100	5.9	3.5	52.9	52.2	51.3	4.8	3.1	51.5	50.8	50.1	3.7	2.7	50.2	49.6	49.0
			200	9.2	5.7	58.3	57.0	54.8	7.5	5.2	56.0	54.7	53.0	5.9	4.5	53.9	52.6	51.3
			300	11.2	7.5	61.8	60.0	56.9	9.2	6.8	59.0	57.2	54.8	7.4	6.0	56.2	54.6	52.8
012-C*W-3	1.9	5.14	200	9.7	6.0	57.2	56.1	55.3	7.9	5.4	55.1	54.0	53.4	6.3	4.7	53.1	52.0	51.7
			300	11.9	7.8	60.8	59.2	57.7	9.8	7.1	58.1	56.5	55.4	7.8	6.3	55.5	54.0	53.3
			400	13.4	9.4	63.2	61.2	59.3	11.1	8.6	60.1	58.2	56.8	9.0	7.7	57.1	55.3	54.6
	2.5	7.97	200	10.4	6.2	55.9	54.9	53.4	8.4	5.6	54.1	53.0	51.8	6.6	4.9	52.3	51.3	50.4
			300	13.0	8.2	59.4	57.9	55.5	10.6	7.4	57.0	55.5	53.6	8.4	6.5	54.7	53.2	51.8
			400	14.9	9.9	61.9	60.0	57.0	12.2	9.0	59.1	57.3	54.9	9.8	8.0	56.3	54.6	52.9
	3.4	13.22	200	11.0	6.5	54.8	53.8	51.5	8.9	5.8	53.1	52.1	50.3	7.0	5.0	51.6	50.6	49.2
			300	14.1	8.7	58.1	56.6	53.4	11.5	7.8	55.9	54.5	51.8	9.1	6.8	53.9	52.5	50.4
			400	16.4	10.5	60.6	58.7	54.7	13.4	9.5	58.0	56.2	53.0	10.6	8.4	55.5	53.8	51.3
018-C*W-3	2.6	2.29	400	15.7	10.4	60.8	59.3	57.2	12.9	9.4	58.1	56.7	55.0	10.3	8.4	55.5	54.1	53.0
			500	17.2	12.0	62.7	60.9	58.4	14.3	10.9	59.6	58.0	56.1	11.5	9.8	56.7	55.1	54.0
			600	18.4	13.5	64.1	62.1	59.3	15.4	12.3	60.8	59.0	56.9	12.5	11.2	57.7	55.9	54.7
	3.4	3.37	400	17.2	11.0	59.5	58.0	55.2	14.1	9.9	57.0	55.6	53.4	11.2	8.7	54.7	53.3	51.6
			500	19.1	12.7	61.4	59.7	56.3	15.7	11.5	58.6	57.0	54.3	12.5	10.2	56.0	54.4	52.4
			600	20.7	14.2	62.9	61.0	57.2	17.0	13.0	59.9	58.0	55.1	13.7	11.6	57.0	55.2	53.1
	4.8	5.77	400	18.9	11.6	57.9	56.5	53.0	15.4	10.4	55.7	54.4	51.5	12.1	9.1	53.7	52.4	50.1
			500	21.4	13.5	59.8	58.2	54.0	17.4	12.2	57.4	55.8	52.3	13.8	10.7	55.0	53.5	50.8
			600	23.3	15.2	61.4	59.5	54.8	19.0	13.7	58.7	56.9	53.0	15.1	12.2	56.1	54.3	51.4
024-C*W-3	3.7	4.63	600	23.7	15.5	60.9	59.3	57.9	19.4	14.1	58.2	56.6	55.6	15.5	12.5	55.5	54.1	53.5
			700	25.3	17.1	62.2	60.4	58.7	20.9	15.6	59.3	57.6	56.4	16.8	14.0	56.4	54.8	54.1
			800	26.7	18.7	63.3	61.3	59.5	22.1	17.0	60.2	58.3	57.0	17.8	15.3	57.2	55.4	54.7
	4.9	7.25	600	26.0	16.4	59.5	58.0	55.7	21.3	14.8	57.1	55.6	53.7	16.8	13.1	54.7	53.3	51.9
			700	28.0	18.1	60.9	59.1	56.5	22.9	16.4	58.2	56.5	54.4	18.2	14.6	55.6	54.0	52.5
			800	29.7	19.8	62.0	60.1	57.2	24.4	17.9	59.1	57.3	55.0	19.5	16.0	56.4	54.7	53.0
	6.7	12.16	600	28.3	17.3	58.2	56.7	53.5	23.0	15.5	56.0	54.5	51.9	18.0	13.6	53.9	52.5	50.4
			700	30.7	19.2	59.5	57.8	54.2	25.0	17.2	57.1	55.5	52.5	19.7	15.2	54.8	53.2	50.9
			800	32.8	21.0	60.6	58.8	54.8	26.8	18.9	58.1	56.3	53.0	21.3	16.7	55.6	53.9	51.4
030-C*W-3	4.0	2.67	600	24.8	16.1	60.1	58.7	57.4	20.3	14.5	57.5	56.1	55.2	16.2	12.9	54.9	53.7	53.2
			800	28.0	19.3	62.5	60.8	59.1	23.2	17.6	59.5	57.9	56.7	18.6	15.8	56.6	55.0	54.4
			1000	30.4	22.4	64.2	62.2	60.3	25.4	20.6	61.0	59.1	57.8	20.7	18.5	57.8	56.0	55.4
	5.9	4.84	600	28.0	17.3	58.1	56.8	54.6	22.9	15.5	55.9	54.6	52.8	18.0	13.7	53.8	52.5	51.2
			800	32.3	21.0	60.7	59.0	56.0	26.5	18.9	58.0	56.4	54.0	21.1	16.8	55.5	54.0	52.2
			1000	35.6	24.3	62.5	60.6	57.1	29.4	22.1	59.6	57.7	55.0	23.6	19.6	56.7	55.0	53.0
	8.0	7.97	600	30.2	18.2	56.8	55.6	52.6	24.5	16.2	54.8	53.6	51.2	19.2	14.2	53.0	51.7	49.8
			800	35.4	22.2	59.3	57.7	53.9	28.9	20.0	56.9	55.3	52.3	22.8	17.5	54.6	53.1	50.7
			1000	39.6	25.7	61.2	59.3	54.9	32.3	23.2	58.5	56.7	53.1	25.7	20.6	55.9	54.2	51.5
036-C*W-3	5.5	4.85	800	33.6	21.7	59.9	58.5	57.3	27.6	19.5	57.3	55.9	55.1	22.0	17.3	54.9	53.5	53.0
			1000	37.1	25.0	61.8	60.1	58.5	30.6	22.7	59.0	57.3	56.2	24.6	20.3	56.2	54.6	54.0
			1200	40.0	28.1	63.3	61.3	59.6	33.1	25.7	60.2	58.3	57.1	26.8	23.1	57.2	55.4	54.8
	7.4	7.87	800	36.8	22.9	58.5	57.1	55.0	30.0	20.6	56.2	54.8	53.2	23.8	18.0	54.0	52.7	51.5
			1000	41.3	26.5	60.4	58.7	56.2	33.7	23.9	57.8	56.2	54.1	26.8	21.2	55.3	53.8	52.3
			1200	44.7	29.8	62.0	60.1	57.1	36.7	27.0	59.1	57.3	55.0	29.4	24.1	56.4	54.7	53.0
	9.5	11.98	800	39.3	23.9	57.4	56.0	53.3	31.9	21.3	55.3	54.0	51.7	25.1	18.6	53.4	52.1	50.3
			1000	44.4	27.7	59.3	57.7	54.4	36.1	24.9	56.9	55.3	52.6	28.5	22.0	54.7	53.1	51.0
			1200	48.6	31.3	60.9	59.0	55.2	39.7	28.2	58.2	56.5	53.4	31.4	25.0	55.7	54.0	51.7

## C\*W-4 Coil Capacities

Ent Wtr	GPM	PD FT.	CFM	85 deg.F DB/71 deg.F WB				LWT	80 deg.F DB/67 deg.F WB				LWT	75 deg.F DB/63 deg.F WB				LWT
				TTL	SENS	LVG AIR		Deg F	TTL	SENS	LVG AIR		Deg F	TTL	SENS	LVG AIR		Deg F
				MBH	MBH	DB	WB		MBH	MBH	DB	WB		MBH	MBH	DB	WB	
006-C*W-4	1.3	3.32	100	6.2	3.6	51.4	51.2	54.6	5.0	3.2	50.2	49.9	52.8	3.9	2.8	49.1	48.8	51.1
			200	9.3	5.9	57.4	56.7	59.5	7.7	5.4	55.0	54.4	56.9	6.1	4.8	52.8	52.2	54.6
			300	11.1	7.7	61.0	60.0	62.3	9.3	7.1	58.0	57.1	59.4	7.6	6.4	55.2	54.3	56.7
	1.7	5.00	100	6.4	3.7	50.4	50.1	52.6	5.2	3.3	49.3	49.1	51.2	4.1	2.9	48.4	48.2	49.9
			200	10.2	6.3	55.8	55.2	57.1	8.3	5.6	53.8	53.2	54.9	6.6	5.0	51.9	51.3	52.9
			300	12.4	8.2	59.5	58.6	59.8	10.3	7.5	56.8	56.0	57.2	8.3	6.7	54.3	53.5	54.8
	2.3	8.10	100	6.6	3.8	49.4	49.2	50.8	5.4	3.4	48.6	48.4	49.7	4.2	2.9	47.9	47.6	48.7
			200	11.0	6.6	54.2	53.7	54.7	9.0	5.9	52.5	52.0	52.9	7.1	5.2	51.0	50.4	51.2
			300	13.8	8.7	57.9	57.0	57.1	11.3	7.9	55.5	54.7	54.9	9.0	7.0	53.3	52.5	52.9
012-C*W-4	2.3	9.10	200	11.5	6.8	53.2	52.7	55.1	9.4	6.1	51.7	51.2	53.2	7.4	5.3	50.3	49.8	51.5
			300	14.6	9.1	56.8	56.1	57.8	11.9	8.2	54.6	53.9	55.5	9.5	7.2	52.6	51.9	53.3
			400	16.7	11.0	59.4	58.4	59.7	13.8	10.0	56.8	55.8	57.1	11.1	8.9	54.3	53.4	54.7
	3.0	14.12	200	12.1	7.1	52.1	51.6	53.1	9.8	6.3	50.8	50.3	51.6	7.7	5.5	49.6	49.1	50.2
			300	15.7	9.5	55.4	54.7	55.6	12.8	8.5	53.5	52.8	53.6	10.1	7.5	51.8	51.1	51.8
			400	18.3	11.6	58.0	57.1	57.3	15.0	10.4	55.7	54.8	55.1	11.9	9.3	53.5	52.6	53.0
	4.1	23.85	200	12.6	7.3	51.0	50.6	51.2	10.2	6.5	50.0	49.5	50.0	8.0	5.6	49.0	48.5	48.9
			300	16.8	10.0	54.1	53.4	53.3	13.6	8.9	52.4	51.8	51.7	10.7	7.7	51.0	50.3	50.3
			400	20.0	12.2	56.5	55.6	54.8	16.2	11.0	54.5	53.6	53.0	12.8	9.6	52.6	51.7	51.3
018-C*W-4	2.6	2.29	400	15.7	10.4	60.8	59.3	57.2	12.9	9.4	58.1	56.7	55.0	10.3	8.4	55.5	54.1	53.0
			500	17.2	12.0	62.7	60.9	58.4	14.3	10.9	59.6	58.0	56.1	11.5	9.8	56.7	55.1	54.0
			600	18.4	13.5	64.1	62.1	59.3	15.4	12.3	60.8	59.0	56.9	12.5	11.2	57.7	55.9	54.7
	3.4	3.37	400	17.2	11.0	59.5	58.0	55.2	14.1	9.9	57.0	55.6	53.4	11.2	8.7	54.7	53.3	51.6
			500	19.1	12.7	61.4	59.7	56.3	15.7	11.5	58.6	57.0	54.3	12.5	10.2	56.0	54.4	52.4
			600	20.7	14.2	62.9	61.0	57.2	17.0	13.0	59.9	58.0	55.1	13.7	11.6	57.0	55.2	53.1
	4.8	5.77	400	18.9	11.6	57.9	56.5	53.0	15.4	10.4	55.7	54.4	51.5	12.1	9.1	53.7	52.4	50.1
			500	21.4	13.5	59.8	58.2	54.0	17.4	12.2	57.4	55.8	52.3	13.8	10.7	55.0	53.5	50.8
			600	23.3	15.2	61.4	59.5	54.8	19.0	13.7	58.7	56.9	53.0	15.1	12.2	56.1	54.3	51.4
024-C*W-4	4.7	8.68	600	29.5	18.2	56.7	56.0	57.6	24.1	16.4	54.5	53.8	55.3	19.1	14.5	52.5	51.8	53.2
			700	31.8	20.3	58.1	57.3	58.6	26.2	18.3	55.7	54.9	56.2	20.9	16.2	53.4	52.6	53.9
			800	33.9	22.2	59.3	58.3	59.5	27.9	20.1	56.7	55.8	57.0	22.4	17.9	54.2	53.3	54.6
	6.1	13.39	600	31.7	19.1	55.4	54.6	55.4	25.8	17.1	53.5	52.8	53.5	20.4	15.0	51.7	51.0	51.7
			700	34.5	21.4	56.7	55.9	56.4	28.2	19.1	54.6	53.8	54.3	22.3	16.8	52.6	51.8	52.4
			800	36.9	23.4	58.0	57.0	57.2	30.3	21.1	55.6	54.7	55.0	24.1	18.5	53.4	52.5	52.9
	8.2	22.08	600	33.7	20.0	54.1	53.4	53.3	27.4	17.8	52.4	51.8	51.7	21.5	15.5	51.0	50.3	50.3
			700	37.1	22.4	55.4	54.6	54.1	30.2	20.0	53.5	52.7	52.4	23.8	17.4	51.8	51.0	50.8
			800	40.2	24.6	56.5	55.6	54.8	32.6	22.0	54.5	53.6	53.0	25.8	19.3	52.6	51.7	51.3
030-C*W-4	5.0	2.75	600	29.4	18.3	56.6	56.0	56.8	24.1	16.5	54.4	53.8	54.7	19.1	14.6	52.4	51.8	52.7
			800	33.8	22.3	59.2	58.4	58.6	27.9	20.2	56.6	55.8	56.2	22.4	18.0	54.1	53.3	54.0
			1000	37.1	25.8	61.1	60.1	59.9	30.9	23.6	58.2	57.2	57.4	25.0	21.2	55.4	54.4	55.1
	7.0	4.65	600	32.4	19.5	54.8	54.2	54.3	26.4	17.4	53.0	52.4	52.6	20.8	15.3	51.3	50.8	51.0
			800	38.0	23.9	57.4	56.6	55.9	31.0	21.5	55.1	54.3	53.9	24.7	18.9	53.0	52.3	52.1
			1000	42.3	27.7	59.4	58.4	57.1	34.7	25.1	56.8	55.8	55.0	27.8	22.3	54.3	53.4	53.0
	9.0	7.03	600	34.2	20.3	53.6	53.1	52.6	27.8	18.0	52.1	51.5	51.2	21.8	15.7	50.6	50.1	49.9
			800	40.8	25.0	56.1	55.3	54.1	33.2	22.4	54.1	53.4	52.4	26.2	19.5	52.2	51.5	50.9
			1000	45.9	29.0	58.1	57.2	55.2	37.5	26.2	55.8	54.8	53.4	29.8	23.2	53.5	52.7	51.7
036-C*W-4	7.0	5.13	800	40.2	24.8	56.3	55.6	56.5	32.8	22.3	54.2	53.5	54.4	26.0	19.6	52.2	51.6	52.5
			1000	45.0	28.8	58.3	57.5	57.9	36.9	26.1	55.9	55.0	55.6	29.5	23.2	53.6	52.8	53.5
			1200	48.9	32.5	59.9	58.9	59.0	40.4	29.5	57.2	56.2	56.6	32.4	26.4	54.6	53.7	54.3
	8.7	7.34	800	42.7	25.8	55.1	54.5	54.8	34.7	23.1	53.3	52.6	53.0	27.4	20.2	51.6	50.9	51.3
			1000	48.3	30.1	57.1	56.3	56.1	39.5	27.1	54.9	54.1	54.1	31.3	23.9	52.9	52.1	52.2
			1200	52.8	34.0	58.8	57.8	57.2	43.4	30.7	56.3	55.4	55.0	34.6	27.3	53.9	53.0	53.0
	10.0	9.29	800	44.1	26.4	54.5	53.8	53.8	35.7	23.5	52.8	52.1	52.2	28.2	20.6	51.2	50.5	50.7
			1000	50.2	30.8	56.4	55.6	55.1	40.9	27.7	54.4	53.6	53.2	32.3	24.3	52.5	51.7	51.5
			1200	55.2	34.9	58.1	57.1	56.1	45.2	31.4	55.7	54.8	54.1	35.8	27.8	53.5	52.6	52.2

## I Row Heating

**006-C\*W-IHW**

Ent Wtr	GPM	PD FT.	CFM	60 DegF Ent Air		
				TTL MBH	LAT F	LWT F
180	0.5	1.19	100	6.8	122.6	152.6
			200	8.9	101.0	144.1
			300	10.1	91.0	139.3
	1.0	2.75	100	7.4	128.3	165.1
			200	10.1	106.7	159.6
			300	11.8	96.2	156.2
	1.5	4.99	100	7.6	130.4	169.7
			200	10.6	109.0	165.7
			300	12.5	98.4	163.2

**012-C\*W-IHW**

Ent Wtr	GPM	PD FT.	CFM	60 DegF Ent Air		
				TTL MBH	LAT F	LWT F
180	0.5	1.29	200	9.7	104.9	140.7
			300	11.1	94.1	135.3
			400	12.0	87.7	131.6
	1.5	5.63	200	11.6	113.7	164.3
			300	13.8	102.4	161.5
			400	15.3	95.4	159.4
	2.5	12.71	200	12.1	115.9	170.2
			300	14.5	104.5	168.3
			400	16.2	97.5	166.9

**018-C\*W-IHW**

Ent Wtr	GPM	PD FT.	CFM	60 DegF Ent Air		
				TTL MBH	LAT F	LWT F
180	0.5	1.59	400	14.6	93.6	121.1
			500	15.4	88.5	117.7
			600	16.1	84.8	115.0
	1.5	7.55	400	19.1	104.0	154.3
			500	20.8	98.2	152.1
			600	22.2	93.9	150.3
	2.5	17.26	400	20.3	106.7	163.7
			500	22.2	100.9	162.1
			600	23.8	96.5	160.8

**024-C\*W-IHW**

Ent Wtr	GPM	PD FT.	CFM	60 DegF Ent Air		
				TTL MBH	LAT F	LWT F
180	1.0	5.04	600	23.5	95.9	132.8
			700	24.6	92.3	130.6
			800	25.5	89.3	128.7
	2.0	15.13	600	27.0	101.4	152.8
			700	28.6	97.5	151.3
			800	30.0	94.4	149.9
	3.0	29.58	600	28.4	103.5	161.0
			700	30.2	99.6	159.8
			800	31.7	96.4	158.8

**030-C\*W-IHW**

Ent Wtr	GPM	PD FT.	CFM	60 DegF Ent Air		
				TTL MBH	LAT F	LWT F
180	2.0	3.31	600	29.3	104.9	150.5
			800	32.5	97.3	147.4
			1000	34.9	92.1	144.9
	3.0	6.11	600	31.1	107.7	159.1
			800	34.8	100.0	156.7
			1000	37.8	94.7	154.7
	4.0	9.66	600	32.1	109.2	163.9
			800	36.1	101.5	161.9
			1000	39.4	96.1	160.3

**036-C\*W-IHW**

Ent Wtr	GPM	PD FT.	CFM	60 DegF Ent Air		
				TTL MBH	LAT F	LWT F
180	2.5	5.32	800	37.2	102.7	150.1
			1000	40.4	97.0	147.6
			1200	42.9	92.8	145.6
	3.5	9.04	800	39.2	104.9	157.5
			1000	42.7	99.2	155.5
			1200	45.6	94.8	153.9
	4.5	13.60	800	40.4	106.3	162.0
			1000	44.1	100.4	160.4
			1200	47.2	96.1	159.0

## 2 Row Heating

**006-C\*W-2HW**

Ent Wtr	GPM	PD FT.	CFM	60 DegF Ent Air		
				TTL MBH	LAT F	LWT F
180	0.5	1.91	100	10.0	152.4	139.6
			200	14.1	125.2	122.9
			300	16.3	110.1	114.2
	1.0	5.08	100	10.8	159.7	158.2
			200	16.5	136.0	146.8
			300	20.0	121.3	139.8
	1.5	9.60	100	11.0	162.0	165.1
			200	17.3	140.0	156.7
			300	21.5	125.8	151.2

**012-C\*W-2HW**

Ent Wtr	GPM	PD FT.	CFM	60 DegF Ent Air		
				TTL MBH	LAT F	LWT F
180	0.5	2.12	200	15.1	129.6	119.1
			300	17.4	113.7	109.6
			400	18.9	103.6	103.7
	1.5	10.90	200	18.5	145.3	155.1
			300	23.1	130.9	149.0
			400	26.5	120.8	144.5
	2.5	25.20	200	19.2	148.7	164.5
			300	24.5	135.0	160.3
			400	28.4	125.3	157.2

**018-C\*W-2HW**

Ent Wtr	GPM	PD FT.	CFM	60 DegF Ent Air		
				TTL MBH	LAT F	LWT F
180	2.0	4.15	400	31.8	133.0	148.1
			500	35.4	125.0	144.5
			600	38.4	118.6	141.6
	3.0	7.78	400	33.5	136.9	157.6
			500	37.6	129.1	154.8
			600	41.2	122.8	152.5
	4.0	12.37	400	34.4	138.9	162.7
			500	38.9	131.3	160.5
			600	42.7	125.1	158.6

**024-C\*W-2HW**

Ent Wtr	GPM	PD FT.	CFM	60 DegF Ent Air		
				TTL MBH	LAT F	LWT F
180	3.0	9.71	600	46.4	130.9	149.0
			700	50.0	125.4	146.6
			800	53.1	120.8	144.5
	4.0	15.51	600	48.1	133.5	155.9
			700	52.0	128.1	153.9
			800	55.5	123.5	152.2
	5.0	22.43	600	49.1	135.0	160.3
			700	53.3	129.8	158.6
			800	57.0	125.3	157.2

**030-C\*W-2HW**

Ent Wtr	GPM	PD FT.	CFM	60 DegF Ent Air		
				TTL MBH	LAT F	LWT F
180	4.5	4.43	600	51.9	139.2	156.9
			800	60.3	129.0	153.2
			1000	67.0	121.3	150.2
	5.5	6.06	600	52.9	140.8	160.7
			800	61.8	130.8	157.5
			1000	69.0	123.2	154.9
	6.5	7.94	600	53.7	141.9	163.5
			800	62.9	132.1	160.6
			1000	70.5	124.5	158.3

**036-C\*W-2HW**

Ent Wtr	GPM	PD FT.	CFM	60 DegF Ent Air		
				TTL MBH	LAT F	LWT F
180	6.0	7.93	800	67.2	136.9	157.6
			1000	75.5	129.1	154.8
			1200	82.4	122.8	152.5
	7.0	10.20	800	68.2	138.0	160.5
			1000	76.9	130.3	158.0
			1200	84.1	124.1	156.0
	8.0	12.73	800	69.0	138.9	162.7
			1000	77.9	131.3	160.5
			1200	85.4	125.1	158.6

### 3 ROW HEATING

**006-C\*W-3**

Ent Wtr	GPM	PD FT.	CFM	60 DegF Ent Air		
				TTL MBH	LAT F	LWT F
180	1.0	1.58	100	11.9	169.6	156.0
			200	19.1	148.3	141.4
			300	23.7	132.5	132.4
	1.4	2.42	100	12.1	171.5	162.6
			200	20.2	152.7	151.0
			300	25.4	137.9	143.5
	1.9	3.72	100	12.2	172.6	167.0
			200	20.8	155.6	158.0
			300	26.7	141.7	151.8

**012-C\*W-3**

Ent Wtr	GPM	PD FT.	CFM	60 DegF Ent Air		
				TTL MBH	LAT F	LWT F
180	1.9	4.17	200	21.8	160.3	156.9
			300	28.4	146.9	150.0
			400	33.3	136.4	144.8
	2.5	6.35	200	22.2	162.1	162.1
			300	29.3	149.6	156.5
			400	34.6	139.5	152.2
	3.4	10.36	200	22.6	163.7	166.7
			300	30.0	151.9	162.3
			400	35.8	142.3	158.8

**018-C\*W-3**

Ent Wtr	GPM	PD FT.	CFM	60 DegF Ent Air		
				TTL MBH	LAT F	LWT F
180	2.6	1.99	400	38.8	149.0	150.1
			500	44.1	140.8	146.0
			600	48.4	133.9	142.7
	3.4	2.87	400	40.1	151.8	156.4
			500	45.9	144.0	153.0
			600	50.7	137.4	150.1
	4.8	4.81	400	41.3	154.5	162.8
			500	47.6	147.2	160.1
			600	53.0	140.9	157.9

**024-C\*W-3**

Ent Wtr	GPM	PD FT.	CFM	60 DegF Ent Air		
				TTL MBH	LAT F	LWT F
180	3.7	3.88	600	56.7	146.6	149.3
			700	61.9	141.0	146.5
			800	66.5	136.0	144.0
	4.9	5.98	600	58.6	149.4	156.0
			700	64.3	144.1	153.7
			800	69.3	139.3	151.7
	6.7	9.91	600	60.1	151.8	162.0
			700	66.3	146.7	160.2
			800	71.8	142.1	158.6

**030-C\*W-3**

Ent Wtr	GPM	PD FT.	CFM	60 DegF Ent Air		
				TTL MBH	LAT F	LWT F
180	4.0	2.38	600	60.4	152.2	149.8
			800	71.4	141.7	144.3
			1000	80.0	133.2	140.0
	5.9	4.23	600	62.8	155.9	158.7
			800	75.4	146.3	154.4
			1000	85.5	138.3	151.0
	8.0	6.89	600	64.2	158.0	163.9
			800	77.7	148.9	160.6
			1000	88.8	141.2	157.8

**036-C\*W-3**

Ent Wtr	GPM	PD FT.	CFM	60 DegF Ent Air		
				TTL MBH	LAT F	LWT F
180	5.5	4.21	800	79.3	150.7	151.1
			1000	90.4	142.7	147.1
			1200	99.5	135.9	143.8
	7.4	6.75	800	81.6	153.4	157.9
			1000	93.8	145.9	154.6
			1200	104.1	139.4	151.8
	9.5	10.21	800	83.2	155.2	162.5
			1000	96.1	147.9	159.8
			1200	107.1	141.7	157.4

HOT WATER HEATING CORRECTION FACTORS									
Entering Air Temp (F)	Entering Water Temp (F)								
	100°	110°	120°	130°	140°	150°	160°	170°	180°
50°	.419	.500	.579	.665	.742	.838	.917	1.000	1.090
55°	.376	.460	.544	.629	.708	.791	.873	.963	1.048
60°	.335	.419	.500	.579	.665	.742	.838	.917	1.000
65°	.290	.376	.460	.544	.629	.708	.791	.873	.963
70°	.251	.335	.419	.500	.579	.665	.742	.838	.917
75°	.205	.290	.376	.460	.544	.629	.708	.791	.873
80°	.167	.251	.335	.419	.500	.579	.665	.742	.838

# 4 ROW HEATING

**006-C\*W-4**

Ent Wtr	GPM	PD FT.	CFM	60 DegF Ent Air		
				TTL MBH	LAT F	LWT F
180	1.3	2.75	100	12.8	171.6	161.2
			200	22.1	161.5	145.8
			300	28.5	147.3	136.0
	1.7	4.04	100	12.9	172.5	165.5
			200	22.7	164.1	153.2
			300	29.8	151.2	144.8
2.3	6.42	100	4.4	93.3	176.8	
		200	23.1	166.3	159.8	
		300	30.9	154.5	153.0	

**012-C\*W-4**

Ent Wtr	GPM	PD FT.	CFM	60 DegF Ent Air		
				TTL MBH	LAT F	LWT F
180	2.3	7.25	200	23.9	169.7	159.1
			300	32.4	159.2	151.7
			400	39.1	149.5	145.9
	3.0	11.09	200	24.1	170.9	163.8
			300	33.1	161.3	157.8
			400	40.3	152.3	153.1
4.1	18.50	200	24.3	171.9	168.1	
		300	33.7	163.1	163.5	
		400	41.4	154.8	159.8	

**018-C\*W-4**

Ent Wtr	GPM	PD FT.	CFM	60 DegF Ent Air		
				TTL MBH	LAT F	LWT F
180	3.0	2.96	400	43.9	160.6	150.7
			500	50.9	153.3	146.0
			600	56.7	146.7	142.1
	4.3	5.07	400	45.2	163.6	158.9
			500	53.0	157.0	155.3
			600	59.6	151.0	152.2
6.0	8.62	400	46.0	165.5	164.6	
		500	54.3	159.5	161.9	
		600	61.5	153.9	159.5	

**024-C\*W-4**

Ent Wtr	GPM	PD FT.	CFM	60 DegF Ent Air		
				TTL MBH	LAT F	LWT F
180	4.7	7.10	600	65.1	159.4	152.3
			700	72.2	154.4	149.2
			800	78.5	149.8	146.6
	6.1	10.83	600	66.5	161.4	158.2
			700	74.0	156.8	155.7
			800	80.8	152.5	153.5
8.2	17.70	600	67.6	163.1	163.5	
		700	75.6	158.8	161.5	
		800	82.8	154.8	159.8	

**030-C\*W-4**

Ent Wtr	GPM	PD FT.	CFM	60 DegF Ent Air		
				TTL MBH	LAT F	LWT F
180	5.0	2.53	600	67.6	163.1	153.0
			800	82.1	153.9	147.1
			1000	93.8	145.8	142.5
	7.0	4.21	600	69.3	165.7	160.2
			800	85.3	157.5	155.6
			1000	98.5	150.1	151.8
9.0	6.33	600	70.2	167.1	164.4	
		800	87.0	159.5	160.7	
		1000	101.1	152.6	157.5	

**036-C\*W-4**

Ent Wtr	GPM	PD FT.	CFM	60 DegF Ent Air		
				TTL MBH	LAT F	LWT F
180	7.0	4.59	800	89.2	162.0	154.5
			1000	103.8	155.1	150.3
			1200	116.3	148.7	146.7
	8.7	6.54	800	90.6	163.6	159.2
			1000	106.1	157.1	155.6
			1200	119.5	151.2	152.5
10.0	8.25	800	91.3	164.5	161.7	
		1000	107.4	158.3	158.5	
		1200	121.2	152.5	155.7	

HOT WATER HEATING CORRECTION FACTORS									
Entering Air Temp (F)	Entering Water Temp (F)								
	100°	110°	120°	130°	140°	150°	160°	170°	180°
50°	.419	.500	.579	.665	.742	.838	.917	1.000	1.090
55°	.376	.460	.544	.629	.708	.791	.873	.963	1.048
60°	.335	.419	.500	.579	.665	.742	.838	.917	1.000
65°	.290	.376	.460	.544	.629	.708	.791	.873	.963
70°	.251	.335	.419	.500	.579	.665	.742	.838	.917
75°	.205	.290	.376	.460	.544	.629	.708	.791	.873
80°	.167	.251	.335	.419	.500	.579	.665	.742	.838



## FLOOR EXPOSED VERTICAL FAN COILS

### 3 & 4 ROW CHILLED WATER COOLING WITH OPTIONAL ELECTRIC OR HOT WATER HEAT

Model Size	SERIES DESIGNATION		ELECTRIC HEAT ADDERS (KV)*							HOT WATER HEAT ADDERS	
	CFW-3	CFW-4	1.0	1.5	2.0	3.0	4.0	5.0	6.0	1 ROW	2 ROW
006	✓	✓	✓	✓	NA	NA	NA	NA	NA	✓	✓
012	✓	✓	✓	✓	✓	✓	NA	NA	NA	✓	✓
018	✓	✓	✓	✓	✓	✓	✓	NA	NA	✓	✓
024	✓	✓	NA	NA	✓	✓	✓	NA	NA	✓	✓
030	✓	✓	NA	NA	✓	✓	✓	✓	✓	✓	✓
036	✓	✓	NA	NA	NA	NA	✓	✓	✓	✓	✓

- As standard equipment all units are equipped with 3 speed Direct Drive 115v single phase motor.
- All units with electric heat are equipped with contactor for 115v control (24v is available).
- Coil options are 3, 4, 3/1 split, 4/1 split, 1/3 split, 2/3 split, 1/4 split and 5 row (maximum). Split coils for four pipe systems are same end connection. **Use 4/1 split for 5 row coil pricing.**
- Consult factory for selected thermostat and valve cluster combinations and pricing.

#### MOTOR OPTIONS (Contact factory for availability)

OPTIONS	MODEL NUMBER					
	006-CF	012-CF	018-CF	024-CF	030-CF	036-CF
220v/1Ø 50Hz motor	✓	✓	✓	✓	✓	✓
277/1/60	✓	✓	✓	✓	✓	✓



## WIRING DIAGRAM CFW SERIES

### DUAL MOTOR ON 036 MODEL ONLY

CONNECT TO AN  
APPROPRIATE  
LINE VOLTAGE  
THERMOSTAT  
AND FAN SWITCH

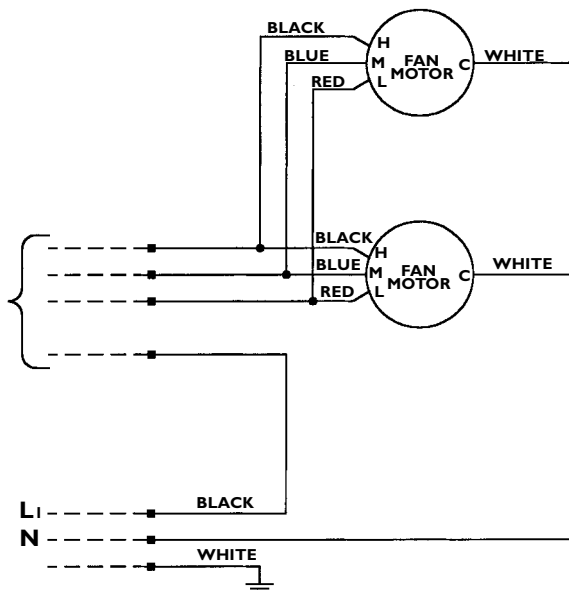

### FOR FAN COIL UNITS SERIES

#### WATER (2-WAY)

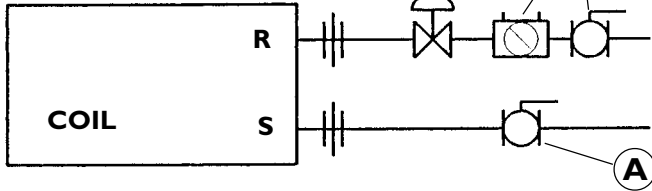

#### WATER (3-WAY)

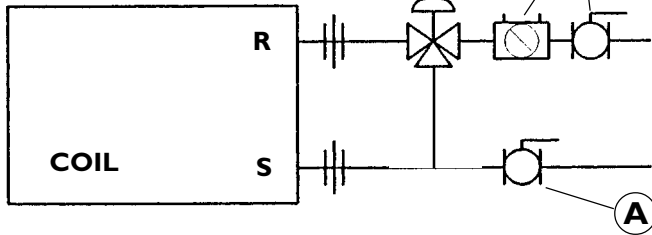

	COMPONENTS	VOLTS	SIZE
A SERVICE VALVES	BALL VALVES (BALANCE VAL)		1/2
			3/4
	GATE VALVES		1/2 3/4
B CONTROL VALVES	2-WAY MOTORIZED	24	1/2
		115	1/2
		24	3/4
	3-WAY MOTORIZED	115	3/4
		24	1/2
		115	1/2
C FLOW CONTROL (NOT BOTH AT SAME TIME)	BALL VALVE W/ MEMORY STOP -OR- CIRCUIT SETTER (3 WEEKS)		1/2
			3/4
			1/2
			3/4

1. VALVE SIZE: 5/8 (1/2) OR 7/8 (3/4).
2. CONTROL VOLTAGE (24, 115).
3. 2-WAY OR 3-WAY MOTORIZED VALVES, TWO-POSITION, SPRING RETURN, NORMALLY CLOSED CONTROL VALVES WITH MANUAL OPENING LEVER.

## CFW COIL CONNECTION DIMENSIONS

### LEFT HAND SHOWN

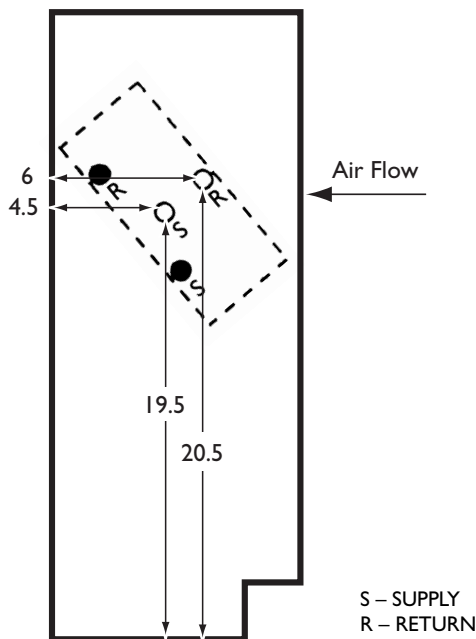

Preheat 3-1, 4-1 Split Coil

UNIT	A	B	C	E
006-036-CFW-3-A	5.438			
006-036-CFW-4-A	6.313			
006-036-CFW-5-A	7.188			
006-036-CFW-31-A		4.500	6.250	
006-036-CFW-41-A		4.500	7.125	
006-036-CFW-32-A		5.375	7.125	
006-036-CFW-13-A				6.313
006-036-CFW-14-A				7.188
006-036-CFW-23-A				7.188

S - SUPPLY  
R - RETURN

O - CHILLED WATER  
● - HOT WATER

**BACK COVER**